

# ANDELI

## **ANDELI GROUP CO.,LTD.**

Add: No.208,Weiqi Road,Yueqing Economic Development Zone,  
Yueqing,Zhejiang,China

Tel: 0086-577-6273 1666

Fax: 0086-577-6273 1777

E-mail: [andeli@andeligroup.com](mailto:andeli@andeligroup.com)

[Http://www.andeligroup.com](http://www.andeligroup.com)

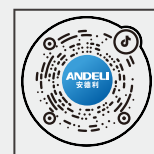

# ANDELI



## POWER TRANSFORMERS SELECTION MANUAL

ANDELI GROUP CO.,LTD.





## Brief Introduction

[www.andeligroup.com](http://www.andeligroup.com)

**Andeli Group** is a professional manufacturer with electrical as its core industry, integrating research and development, production, sales, and service. The company has been awarded multiple honors, including Top 10 Growth Enterprises in China's Electrical Industry, National Customer Satisfaction Enterprise, National High tech Enterprise, National Ministry of Industry and Information Technology Green Factory, National Specialized and Innovative Small Giant Enterprise, and National Ministry of Industry and Information Technology Green Supply Chain Management Enterprise.

Andeli Group adheres to the mission of providing customers with satisfactory power products and solutions. We mainly research and develop complete sets of transmission and distribution equipment, power transformers, high and low voltage electrical components, instruments and meters, welding equipment, new energy and other series. The product is widely used in many fields such as State Grid, Southern Power Grid, Inner Mongolia Power Grid and rail transit, commercial housing, energy and chemical industry, metal smelting, and power management. Andeli actively implements a globalization strategy and has established branch offices in the United Arab Emirates, Russia, Brazil, Pakistan, Thailand, Saudi Arabia, and other places. Its products are exported to more than 100 countries and regions around the world.

Andeli people, who uphold the principles of honesty and diligence in their work, sincerely work hand in hand with elites from all walks of life to create a better future together.

# OIL-IMMERSED TRANSFORMERS



## ■ 6-10kV series oil immersed distribution transformer

### 1、 Product overview

---

#### 1.1 Characteristics

- 1、 Our company's improved oil immersed distribution transformer iron core is made of imported high-quality cold-rolled silicon steel sheets stacked together, greatly reducing no-load losses and no-load currents. The iron core is tied to ensure its compactness and reduce noise.
- 2、 The transformer connection group adopts the Dyn11 wiring method to reduce the impact of harmonics on the power grid and improve the quality of power supply.
- 3、 The transformer is a fully sealed structure that extends its service life, eliminates the need for hanging cores, and requires no maintenance.
- 4、 The high and low voltage windings are made of oxygen free copper. For low voltage windings of 500kVA and below, a double-layer cylindrical structure is used. For windings of 630kVA and above, a double helix or four helix structure is used. For high voltage windings, a multi-layer cylindrical structure is used.
- 5、 The measured noise level is lower than the standard.

#### 1.2 Normal operating conditions

Altitude: The altitude shall not exceed 1000m;

Environmental temperature: Maximum temperature+40 °C;

Maximum daily average temperature+30 °C;

The highest annual average temperature is+20 °C; The minimum outdoor temperature is -25 °C;

The waveform of the power supply voltage is approximately a sine wave.

The three-phase power supply voltage should be roughly symmetrical;

Installation environment: No obvious pollution;

Ground acceleration caused by earthquakes: Horizontal direction less than  $3m/s^2$ , Vertical direction less than  $1.5m/s^2$

Indoor use

Note: Any special usage conditions that need to be met beyond the normal usage conditions of the transformer should be specified during the inquiry and ordering process.

### 2、 Model Description

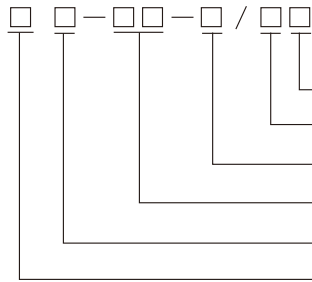

Special use environment (WZ seismic WFZ anti-corrosion seismic GY plateau)  
 Voltage level(kV)  
 Rated capacity(kVA)  
 Special purpose or special structure code (R-coil iron core M-fully sealed)  
 Performance level code (11 13 14 20 22)  
 Product model (D-single-phase S-three-phase F-air-cooled Z-on load voltage regulation)

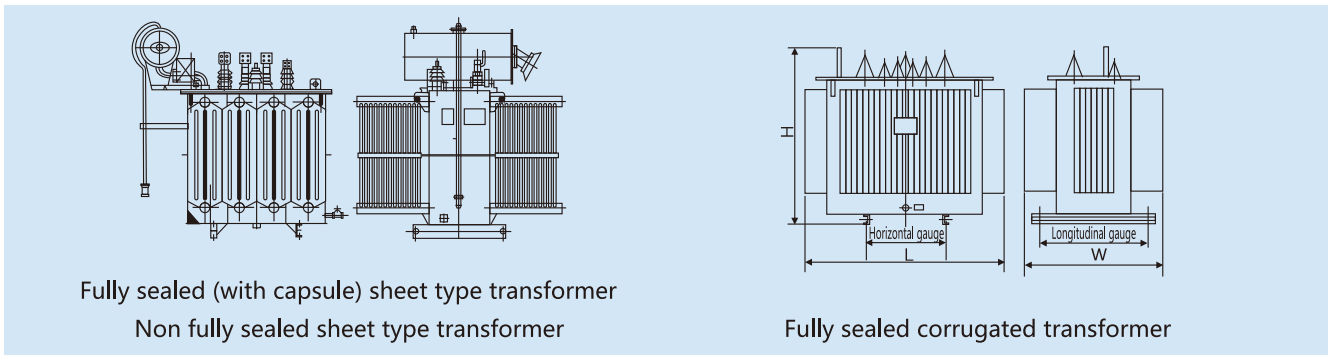

Fully sealed (with capsule) sheet type transformer  
 Non fully sealed sheet type transformer

Fully sealed corrugated transformer

### 3、 Technical Parameter

#### 3.1 6kV-10kV S11 series oil immersed non excited voltage regulating distribution transformer

Rated Capacity (kVA)	Rated voltage and tap range		Connecting groups	Loss W		No-load current	Impedance Voltage %	Weight kg			External dimensions L*B*H	Track gauge portrait/landscape	
	HV	Tap range		LV	No-load			Load 75°C	Body weight	Oil			Total weight
30	11 10.5 10 6.3 6	±5 ±2×2.5	0.4	Dyn11 Yzn11 Yyn0	100	100	1.5	4.0	135	55	325	680*480*846	550/400
50					130	130	1.3		210	75	435	765*690*876	
63					150	150	1.2		245	85	490	795*645*915	
80					180	180	1.2		290	90	550	825*660*925	
100					200	200	1.1		315	95	590	810*770*980	
125					240	240	1.1		365	100	660	825*800*960	
160					280	280	1.0		440	115	720	1115*735*985	
200					340	340	1.0		490	160	790	1186*815*1050	
250					400	400	0.9		600	150	960	1290*860*1050	
315					480	480	0.9		710	180	1120	1350*920*1090	
400				570	570	0.8	920	210	1440	1485*1030*1120			
500				680	680	0.8	1050	320	1800	1470*1030*1160			
630				810	810	0.6	1130	260	1770	1550*1045*1225			
800				980	980	0.6	1340	290	2060	1730*1220*1285			
1000				1150	1150	0.6	1440	420	2505	1670*1160*1375			
1250				1360	1360	0.5	1750	480	2970	1750*1240*1425			
1600				1640	1640	0.5	2240	600	3950	1860*1260*1485			
2000				1940	1940	0.4	2575	635	4305	1990*1315*1620			
2500				2290	2290	0.4	3270	815	5440	2065*1360*1750			
										5.0			
												1070/1070	

Note: ① For three-phase transformers with a rated capacity of 500kVA or less, the load loss values above the diagonal lines in the table apply to the Dyn11 or Yzn11 connection group. The load value below the diagonal line is applicable to the Yy0 combination group;  
 ② When the annual average load rate of the transformer is between 35% and 40%, using the losses in the table can achieve the highest operating efficiency

### 3.2 6kV-10kV S11 series oil immersed non excited voltage regulating power transformer

Rated Capacity (kVA)	Rated voltage and tap range		Connecting groups	Loss W		No-load current	Impedance Voltage %	Weight kg			External dimensions L*B*H	Track gauge portrait/landscape
	HV	LV		No-load	Load 75°C			Body weight	Oil	Total weight		
200	10.5 10 6.3 6	6.3 3.15 3	Yd11 Dy11	340	3150	1.8	4.5	650	160	1000	1180*740*1270	660/660
250				400	3600	1.7		770	200	1190	1230*780*1340	
315				480	4300	1.6		900	215	1360	1260*810*1370	
400				570	5200	1.5		1080	260	1650	1380*900*1390	
500				680	6200	1.4		1250	280	1890	1400*920*1450	
630				820	6920	0.6		1470	340	2245	1580*1020*1430	
800				1000	8460	0.6		1735	385	2645	1665*1070*1520	
1000				1180	9910	0.6		1910	430	2980	1740*1160*1550	
1250				1400	11700	0.5		2210	590	3640	1820*1210*1740	
1600				1680	14100	0.4		2640	680	4270	1840*1240*1860	
2000	2010	16900	0.4	2890	725	4775	2210*1920*1970	1070/1070				
2500	2370	19600	0.4	3460	910	5710	2260*1970*1995					
3150	2800	23000	0.4	4230	1350	7085	2320*2280*2360					
4000	3450	27300	0.4	5025	1675	9150	2460*2480*2475					
5000	4100	31300	0.4	6020	1940	9610	2575*2640*2590					
6300	4890	35000	0.4	8125	2550	12660	2640*2820*2810					
8000	6520	40500	0.55	9620	2780	15100	2710*2840*3040					
10000	7700	47700	0.55	11660	3070	17480	2850*2880*3265					
	10.5 10	6.3 3.15									1475/1475	

Note: ① Tapping range of high voltage:  $\pm 5\%$  or  $\pm 2 \times 2.5\%$ ; Frequency 50Hz  
 ② The provided external dimensions are for reference only during selection, and the final dimensions are subject to the product's external drawing

### 3.3 6kV-10kV S13 series three-level energy-efficient oil immersed non excited voltage regulating distribution transformer

Rated Capacity (kVA)	Rated voltage and tap range			Connecting groups	Loss W		No-load current	Impedance Voltage %	Weight kg			External dimensions L*B*H	Track gauge portrait/landscape
	HV	Tap range	LV		No-load	Load 75°C			Body weight	Oil	Total weight		
30	11 10.5 10 6.3 6	$\pm 5$ $\pm 2 \times 2.5$	0.4	Dyn11 Yzn11 Yyn0	80	630/600	1.5	4.0	140	70	320	745*555*830	550/400
50					100	910/870	1.3		205	75	390	775*595*890	
63					110	1090/1040	1.2		240	85	450	790*640*930	
80					130	1310/1250	1.2		290	95	520	857*700*950	
100					150	1580/1500	1.1		340	100	576	845*720*950	
125					170	1890/1800	1.1		390	110	650	850*770*990	
160					200	2310/2200	1.0		470	150	760	1130*770*1013	
200					240	2730/2600	1.0		540	135	861	1160*780*1160	
250					290	3200/3050	0.9		670	160	1030	1220*810*1111	
315					340	3830/3650	0.9		750	173	1160	1280*880*1150	
400	410	4520/4300	0.8	910	210	1390	1320*900*1196	660/660					
500	480	5410/5150	0.8	1070	230	1650	1420*980*1240						
630	570	6200	0.6	1310	290	1960	1510*1010*1310						
800	700	7500	0.6	1550	320	2320	1640*1120*1335						
1000	830	10300	0.6	1595	360	2550	1675*1145*1365						
1250	970	12000	0.5	2110	500	3370	1820*1260*1492						
1600	1170	14500	0.5	2635	600	4190	1940*1300*1625						
2000	1360	18300	0.4	2700	755	4720	2000*1345*1700						
2500	1600	21200	0.4	3240	835	5460	2030*1360*1900						

Note: ① For three-phase transformers with a rated capacity of 500kVA or less, the load loss values above the diagonal lines in the table apply to the Dyn11 or Yzn11 connection group, The load value below the diagonal line is applicable to the Yy0 combination group;  
 ② When the annual average load rate of the transformer is between 35% and 40%, using the losses in the table can achieve the highest operating efficiency

### 3.4 6kV-10kV S20 series secondary energy efficiency oil immersed non excited voltage regulating distribution transformer

Rated Capacity (kVA)	Rated voltage and tap range			Connecting groups	Loss W		No-load current	Impedance Voltage %	Weight kg			External dimensions L*B*H	Track gauge portrait/landscape
	HV	Tap range	LV		No-load	Load 75°C			Body weight	Oil	Total weight		
30	11 10.5 10 6.3 6	±5 ±2×2.5	0.4	Dyn11 Yzn11 Yyn0	70	505/480	1.5	4.0	180	70	370	780*355*860	550/400
50					90	730/695	1.3		288	85	510	860*365*940	
63					100	870/830	1.2		335	95	590	865*370*960	
80					115	1050/1000	1.2		380	100	650	880*380*1015	
100					135	1265/1200	1.1		440	115	735	920*580*1020	
125					150	1510/1440	1.1		525	120	850	930*675*1080	
160					180	1850/1760	1.0		630	150	1010	965*680*1160	
200					215	2185/2080	1.0		760	165	1170	1010*750*1180	
250					260	2560/2440	0.9		865	180	1290	1015*750*1190	
315					305	3065/2920	0.9		1050	210	1560	1095*780*1230	
400				370	3615/3440	0.8	1100	230	1675	1100*900*1260			
500				430	4330/4120	0.8	1420	265	2090	1160*940*1310			
630				510	4960	0.6	1705	300	2450	1250*980*1345			
800				630	6000	0.6	1895	320	2700	1260*990*1360			
1000				745	8240	0.6	2080	360	3045	1615*1095*1450			
1250				870	9600	0.5	2550	470	3790	1705*1100*1520			
1600				1050	11600	0.5	2910	575	1340	1800*1145*1700			
2000				1225	14640	0.4	3525	595	5000	1925*1180*1750			
2500				1440	14840	0.4	4860	690	6490	1945*1230*1990	1070/1070		

### 3.5 6kV-10kV S22 series first level energy-efficient oil immersed non excited voltage regulating distribution transformer

Rated Capacity (kVA)	Rated voltage and tap range			Connecting groups	Loss W		Impedance Voltage %	Weight kg			External dimensions L*B*H	Track gauge portrait/landscape	
	HV	Tap range	LV		No-load	Load 75°C		Body weight	Oil	Total weight			
30	11 10.5 10 6.3 6	±5 ±2×2.5	0.4	Dyn11 Yzn11 Yyn0	65	455/430	1.5	4.0	196	65	385	790*345*870	550/400
50					80	655/625	1.3		320	85	560	845*370*960	
63					90	785/745	1.2		365	90	600	865*380*1000	
80					105	945/900	1.2		430	100	685	895*390*1035	
100					120	1140/1080	1.1		520	115	810	925*515*1045	
125					135	1360/1295	1.1		590	120	900	945*565*1085	
160					160	1665/1585	1.0		715	150	1075	985*570*1120	
200					190	1970/1870	1.0		895	160	1300	1015*605*1150	
250					230	2300/2195	0.9		985	180	1405	1030*640*1200	
315					270	2760/2630	0.9		1200	215	1725	1120*750*1245	
400				330	3250/3095	0.8	1280	220	1845	1150*825*1300			
500				385	3900/3710	0.8	1545	240	3150	1205*845*1400			
630				460	4460	0.6	1890	270	2580	1275*900*1500			
800				560	5400	0.6	2180	335	2990	1365*950*1520			
1000				665	7415	0.6	2260	400	3255	1430*1050*1550			
1250				780	8640	0.5	2890	470	4060	1480*1075*1590			
1600				940	10440	0.5	3260	510	4600	1520*1115*1725			
2000				1085	13180	0.4	4070	650	5600	1565*1235*1830			
2500				1280	13360	0.4	5615	670	7195	1680*1290*2110	1070/1070		

### 3.6 6kV~10kV SZ13 series three-phase double winding on load tap changer distribution transformer

Rated Capacity (kVA)	Rated voltage and tap range			Connecting groups	No-load loss	Load Loss W	No-load current	Impedance Voltage %	
	HV	Tap range	LV						
200	6 6.3 10 10.5	±4×2.5	0.4	Dyn11 Yyn0	300	2900	1.0	4.0	
250					350	3420	0.9		
315					420	4100	0.9		
400					510	4950	0.8		
500					600	5890	0.8		
630					770	7260	0.6		
800					900	8890	0.6		
1000					1000	10400	0.6		
1250					1250	12300	0.5		
1600					1540	14700	0.5		
2000					1820	18600	0.4		
2500					2100	21600	0.4		5.0

## ■ 20kV series oil immersed distribution transformer

### 1.1 20kV S11 series oil immersed non excited voltage regulating distribution transformer

Rated Capacity (kVA)	Rated voltage and tap range			Connecting groups	Loss W		No-load current %	Impedance Voltage %
	HV	Tap range	LV		No-load	Load		
30	20	±5 ±2×2.5	0.4	Dyn11 Yzn11 Yyn0	100	690/660	2.1	5.5
50					130	1010/960	2.0	
63					150	1200/1150	1.9	
80					180	1440/1370	1.8	
100					200	1730/1650	1.6	
125					240	2080/1980	1.5	
160					290	2540/2420	1.4	
200					340	3000/2860	1.3	
250					400	3520/3350	1.2	
315					480	4210/4010	1.1	
400					570	4970/4730	1.0	
500					680	5940/5660	1.0	
630					810	6820	0.9	
800					980	8250	0.8	
1000					1150	11330	0.7	
1250					1380	13200	0.7	
1600					1660	15950	0.6	
2000					1950	19140	0.6	
2500					2340	22220	0.5	

Note: ① For three-phase transformers with a rated capacity of 500kVA or less, the load loss values above the diagonal lines in the table apply to the Dyn11 or Yzn11 connection group, The load value below the diagonal line is applicable to the Yy0 combination group;  
 ② The performance parameters in the table are also applicable to three-phase transformers with high voltage of dual voltage 20 (10) kV

### 1.2 20kV S12 series oil immersed non excited voltage regulating distribution transformer

Rated Capacity (kVA)	Rated voltage and tap range			Connecting groups	Loss W		No-load current %	Impedance Voltage %
	HV	Tap range	LV		No-load	Load		
30	20	±5 ±2×2.5	0.4	Dyn11 Yzn11 Yyn0	90	690/660	2.1	5.5
50					120	1010/960	2.0	
63					140	1200/1150	1.9	
80					160	1440/1370	1.8	
100					180	1730/1650	1.6	
125					220	2080/1980	1.5	
160					260	2540/2420	1.4	
200					310	3000/2860	1.3	
250					360	3520/3350	1.2	
315					430	4210/4010	1.1	
400					510	4970/4730	1.0	
500					610	5940/5660	1.0	
630					730	6820	0.9	
800					880	8250	0.8	
1000					1030	11330	0.7	
1250					1240	13200	0.7	
1600					1490	15950	0.6	
2000					1750	19140	0.6	
2500					2100	22220	0.5	

Note: ① For three-phase transformers with a rated capacity of 500kVA or less, the load loss values above the diagonal lines in the table apply to the Dyn11 or Yzn11 connection group, The load value below the diagonal line is applicable to the Yy0 combination group;  
 ② The performance parameters in the table are also applicable to three-phase transformers with high voltage of dual voltage 20 (10) kV

### 35kV series oil immersed distribution transformer

#### 1.1 35kV S11 series oil immersed non excited voltage regulating distribution transformer

Rated Capacity (kVA)	Rated voltage and tap range			Connecting groups	Loss W		No-load current	Impedance Voltage %	Weight kg			External dimensions L*B*H	Track gauge portrait/landscape
	HV	Tap range	LV		No-load	Load 75°C			Body weight	Oil	Total weight		
30	35 38.5	±5 ±2×2.5	0.4	Dyn11 Yyn0	140	890/840	1.7	6.5	165	230	580	1320*550*1550	550/550
50					160	1200/1140	1.3		230	265	730	1360*700*1680	
80					220	1800/1710	1.1		310	310	870	1395*730*1730	
100					230	2010/1910	1.1		370	340	1000	1440*760*1810	
125					270	2370/2260	1.0		440	380	1120	1450*800*1940	
160					280	2820/2680	1.0		540	415	1360	1470*800*2910	660/660
200					340	3320/3160	1.0		635	455	1540	1500*800*2050	
250					400	3950/3760	0.95		725	490	1745	1530*830*2090	
315					480	4750/4530	0.95		825	525	1910	1550*870*2150	
400					580	5740/5470	0.85		980	595	2220	1600*940*2200	
500					680	6910/6580	0.85		1210	680	2640	1750*1000*2280	820/820
630					830	7860	0.65		1110	800	3175	2130*950*2400	
800					980	9400	0.65		1625	850	3595	2210*1075*2450	
1000					1150	11500	0.65		1955	965	4260	2250*1090*2630	
1250					1400	13900	0.6		2250	1130	4835	2210*1740*2690	
1600					1690	16600	0.6		2890	1260	5995	2250*2145*2700	1070/1070
2000					1990	19700	0.55		3070	1330	6445	2320*2170*2750	
2500					2360	23200	0.55		3555	1390	7080	2340*2180*2510	

Note: ① High voltage can provide a voltage regulation range of ± 5% or ± 2x2.5%  
 ② The load loss values above the diagonal line in the table are applicable to the Dyn11 connection group, and the load loss values below the diagonal line are applicable to the Yyn0 connection group  
 ③ The provided external dimensions are for reference only during selection, and the final dimensions are subject to the product's external drawing

#### 1.2 35kV SZ11 series on load tap changer oil immersed power transformer

Rated Capacity (kVA)	Rated voltage and tap range			Connecting groups	Loss W		No-load current	Impedance Voltage %	Weight kg			External dimensions L*B*H	Track gauge portrait/landscape
	HV	Tap range	LV		No-load	Load 75°C			Body weight	Oil	Total weight		
800	35	±3×2.5	6.3 10.5	Yd11	1250	9880	0.9	6.5	1735	995	3625	2790*1220*2130	660/660
1000					1500	12160	0.9		2015	1105	4055	2830*1240*2150	
1250					1770	14630	0.81		2190	1155	4580	2870*1310*2210	
1600					2160	17480	0.77		2535	1295	5245	2875*1310*2380	
2000					2300	19200	0.5		2855	1345	5935	2980*2880*2380	
2500			2720	20600	0.5	3815	1575		6745	3060*2190*2490	1070/1070		
3150			3230	24700	0.5	4235	1860		8780	3180*2240*2510			
4000			3870	29100	0.5	5230	2260		9820	3270*2410*2600			
5000			4640	34200	0.5	6195	2454		11510	3490*2480*2840			
6300			5630	36700	0.5	8315	3095		14805	3710*2600*3005		1475/1475	
8000	7870	40600	0.4	9870	3480	16590	3850*2680*3230						
10000	9280	48000	0.4	11025	4160	19930	3960*2750*3310						
12500	10000	56800	0.35	14270	5265	24295	4035*2980*3530						
16000	13100	70300	0.35	17780	6280	28720	4140*3200*3660	2040/2040					
20000	15500	72700	0.3	20205	7415	37380	4070*3580*4170						
25000	18300	97800	0.3	24950	9030	43425	4710*4120*4310						
31500	21800	116000	0.3	29820	11025	51555	5360*4570*4450						

Note: ① For transformers with a low voltage of 10.5kV, a product with the connection group number Dyn11 can be provided;  
 ② The maximum current tap position is -7.5% tap position

# TRIANGULAR THREE-DIMENSIONAL COILED IRON CORE TRANSFORMER



## ■ 10kV three-dimensional triangular transformer

### 1、 Product overview

The three-dimensional iron core oil immersed transformer is a new type of high reliability transformer product with a more reasonable structure, better performance, and lower manufacturing cost. The product adopts a three-phase symmetrical three-dimensional structure. And due to the absence of air gaps in its magnetic circuit, the direction of magnetic conductivity of the silicon steel strip is completely consistent with the direction of the magnetic circuit. The three equilateral triangles of the central pillar star are arranged in a three-dimensional manner, and the lengths of the three magnetic circuits are the same, all of which are the shortest, resulting in no waste during processing and cutting; Therefore, it is an efficient and energy-saving transformer that uses traditional materials but has lower operating noise and a more compact structure. Its outstanding performance in reducing losses and saving materials fully complies with China's energy-saving policy.

### 2、 Transformer Model Description

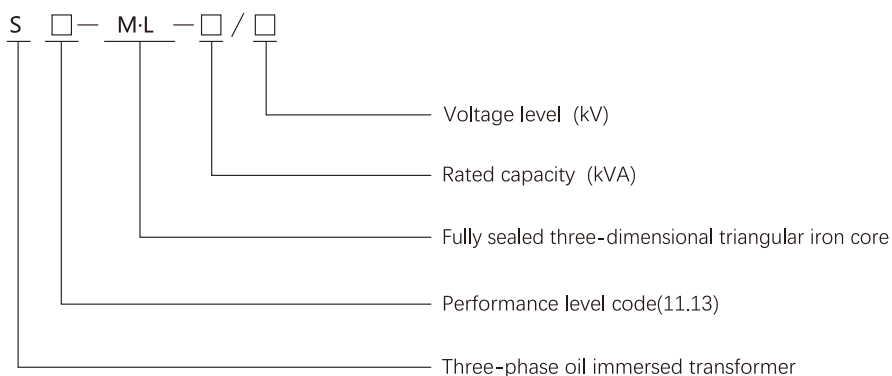

### 4、 Technical parameters and external dimensions of three-dimensional triangular transformer

Rated Capacity (kVA)	Body lifting weight kg	Oil weight kg	Total weight kg	External dimensions mm			Installation size mm			Low voltage phase terminal mm				Low voltage wire terminal mm			
				L	B	H	E1	E2	D	Md	b	b1	d1	Md	b	b1	d1
30	150	80	295	683	627	862	350	550	19	12	35	/	/	12	35	/	/
50	210	95	380	799	692	907	350	550	19	12	35	/	/	12	35	/	/
63	260	125	465	842	729	932	380	550	19	12	35	/	/	12	35	/	/
80	285	130	510	932	744	962	380	550	19	12	35	/	/	12	35	/	/
100	305	130	540	932	807	1015	380	550	19	12	35	/	/	12	35	/	/
125	375	155	655	990	865	1035	400	550	19	12	35	/	/	12	35	/	/
160	440	175	760	1105	957	1065	400	660	19	12	35	/	/	12	35	/	/
200	540	200	905	1139	987	1117	400	660	19	16	40	/	/	12	35	/	/
250	605	215	1000	1223	1059	1152	400	660	19	16	40	/	/	12	35	/	/
315	835	245	1195	1341	1161	1182	400	820	19	20	40	/	/	12	35	/	/
400	835	235	1320	1352	1171	1237	400	820	19	20	40	/	/	12	35	/	/
500	1030	280	1595	1420	1230	1292	550	820	19	24	80	40	14	20	40	/	/
630	1225	365	1950	1468	1270	1372	550	1070	19	24	80	40	14	20	40	/	/
800	1390	485	2325	1597	1383	1439	550	1070	19	30	80	40	14	20	40	/	/
1000	1495	590	2620	1658	1436	1579	550	1070	19	33	100	50	18	24	80	40	14
1250	1880	700	3235	1720	1489	1676	550	1070	19	42	100	50	18	24	80	40	14
1600	2235	815	3815	1730	1498	1856	550	1070	19	42	100	50	18	24	80	40	14
2000	2630	2025	5910	2259	1957	1860	820	1070	19	48	100	50	18	30	80	40	14
2500	3175	2190	6780	2347	2032	1857	820	1070	19	56	100	50	15	33	80	40	14

### Appearance and installation dimensions

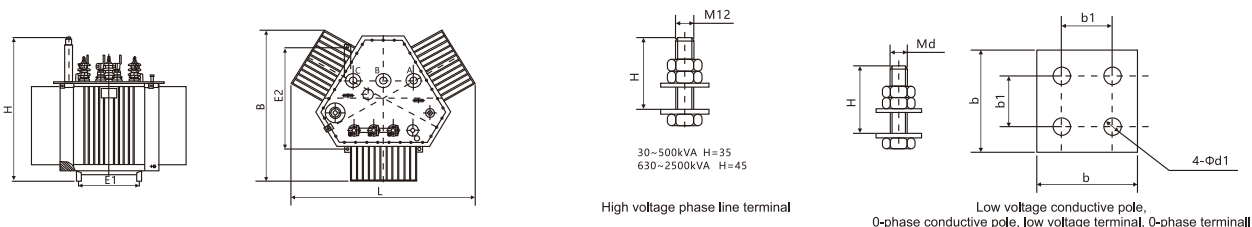

### Technical Parameter

Rated Capacity (kVA)	Rated voltage and tap range			Connecting groups	Loss W		No-load current	Impedance Voltage %	Weight kg			External dimensions L*B*H	Track gauge portrait/landscape
	HV	Tap range	LV		No-load	Load 75°C			Body weight	Oil	Total weight		
30	35 38.5	±5 ±2×2.5	0.4	Dyn11 Yyn0	140	890/840	1.7		165	230	580	1320*550*1550	550/550
50					160	1200/1140	1.3		230	265	730	1360*700*1680	
80					220	1800/1710	1.1		310	310	870	1395*730*1730	
100					230	2010/1910	1.1		370	340	1000	1440*760*1810	
125					270	2370/2260	1.0		440	380	1120	1450*800*1940	
160					280	2820/2680	1.0		540	415	1360	1470*800*2910	
200					340	3320/3160	1.0		635	455	1540	1500*800*2050	660/660
250					400	3950/3760	0.95		725	490	1745	1530*830*2090	
315					480	4750/4530	0.95		825	525	1910	1550*870*2150	
400					580	5740/5470	0.85		980	595	2220	1600*940*2200	
500					680	6910/6580	0.85		1210	680	2640	1750*1000*2280	820/820
630					830	7860	0.65		1110	800	3175	2130*950*2400	
800					980	9400	0.65		1625	850	3595	2210*1075*2450	
1000					1150	11500	0.65		1955	965	4260	2250*1090*2630	
1250					1400	13900	0.6		2250	1130	4835	2210*1740*2690	1070/1070
1600					1690	16600	0.6		2890	1260	5995	2250*2145*2700	
2000	1990	19700	0.55	3070	1330	6445	2320*2170*2750						
2500	2360	23200	0.55	3555	1390	7080	2340*2180*2510						

# DRY-TYPE TRANSFORMER



## ■ 6-10kV SCB series resin insulated dry-type transformer

### 1、 Product overview

---

Low loss, low operating costs, and significant energy-saving effects;  
Flame retardant, fire-resistant, explosion-proof, and pollution-free;  
Good moisture resistance and strong heat dissipation ability;  
Low partial discharge, low noise, maintenance free;  
High mechanical strength, strong short-circuit resistance, and long service life.

### 2、 Transformer Model Description

---

SC Z (B) 11 - XXXX / XX

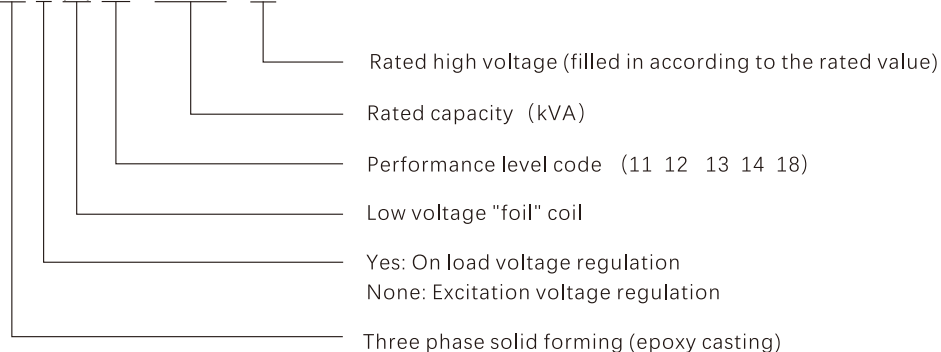

### 3、6kV、10kV technical parameters of dry-type transformer

#### 3.1 SC(B)11 series 6kV、10kV level non excited voltage regulation distribution dry-type transformer

Rated Capacity (kVA)	Rated voltage and tap range			Connecting groups	No-load loss	Load Loss W			No-load current %	Impedance Voltage %				
	HV	Tap range	LV			130°C(B) 100°C	155°C(F) 120°C	180°C(H) 145°C						
30	6	±2×2.5 ±5	0.4	Dyn11 Yyn0	170	670	710	760	2.0	4.0				
50					240	940	1000	1070	2.0					
80					330	1290	1380	1480	1.5					
100					360	1480	1570	1690	1.5					
125					420	1740	1850	1980	1.3					
160					480	2000	2130	2280	1.3					
200					550	2370	2530	2710	1.1					
250					640	2590	2760	2690	1.1					
315					6.3	±2×2.5 ±5	0.4	Dyn11 Yyn0	790		3270	3470	3730	1.0
400					6.6				880		3750	3990	4280	1.0
500					10				1040	4590	4880	5230	1.0	
630					10.5				1200	5530	5880	6290	0.85	
630					11				1170	5610	5960	6400	0.85	
800									1360	6550	6960	7460	0.85	
1000									1590	7650	8130	8760	0.85	
1250									1880	9100	9690	10300	0.85	
1600									2200	11000	11700	12500	0.85	
2000									2740	13600	14400	15500	0.7	
2500						3240	16100	17100	18400	0.7				
1600						2200	12200	12900	13900	0.85				
2000		2740	15000	15900	17100	0.7								
2500		3240	17700	18800	20200	0.7								
									8.0					

Note: The load losses listed in the table are the values of different insulation systems at the reference temperature (specified in GB/T1094.11) in parentheses. The load losses of other insulation systems not included in the table need to be converted based on their respective reference temperatures, using the data of "155 °C (F)" insulation system temperature as a reference.

#### 3.2 SC(B)13 series 6kV、Technical parameters of 10kV level non excited voltage regulation distribution dry-type transformer

Rated Capacity (kVA)	Rated voltage and tap range			Connecting groups	No-load loss	Load Loss W			No-load current %	Impedance Voltage %				
	HV	Tap range	LV			130°C(B) 100°C	155°C(F) 120°C	180°C(H) 145°C						
30	6	±2×2.5 ±5	0.4	Dyn11 Yyn0	135	605	640	685	2.0	4.0				
50					195	845	900	965	2.0					
80					265	1160	1240	1330	1.5					
100					290	1330	1410	1520	1.5					
125					340	1565	1660	1780	1.3					
160					385	1800	1910	2050	1.3					
200					445	2135	2270	2440	1.1					
250					515	2330	2480	2660	1.1					
315					6.3	±2×2.5 ±5	0.4	Dyn11 Yyn0	635		2940	3120	3350	1.0
400					6.6				705		3370	3590	3850	1.0
500					10				835	4130	4390	4700	1.0	
630					10.5				965	4970	5290	5660	0.85	
630					11				935	5050	5360	5760	0.85	
800									1090	5890	6260	6710	0.85	
1000									1270	6880	7310	7880	0.85	
1250									1500	8190	8720	9330	0.85	
1600									1760	9940	10500	11300	0.85	
2000									2190	12200	13000	14000	0.7	
2500						2590	14500	15400	16600	0.7				
1600						1760	11000	11600	12500	0.85				
2000		2190	13500	14300	15400	0.7								
2500		2590	15900	17000	18200	0.7								
									6.0					

Note: The load losses listed in the table are the values of different insulation systems at the reference temperature (specified in GB/T1094.11) in parentheses. The loads under other insulation systems not included in the tableLosses need to be converted based on their respective reference temperatures, using the insulation system temperature data of "155 °C (F)" as a reference.

### 3.3 SC(B)12 series level 3 energy consumption 6kV、10kV level non excited voltage regulation distribution dry-type transformer

Rated Capacity (kVA)	Rated voltage and tap range			Connecting groups	No-load loss	Load Loss W			No-load current %	Impedance Voltage %
	HV	Tap range	LV							
30					150	670	710	760	2.0	4.0
50					215	940	1000	1070	2.0	
80					295	1290	1380	1480	1.5	
100					320	1480	1570	1690	1.5	
125					375	1740	1850	1980	1.3	
160					430	2000	2130	2280	1.3	
200					495	2370	2530	2710	1.1	
250	6				575	2590	2760	2960	1.1	
315	6.3				705	3270	3470	3730	1.0	
400	6.6	±2×2.5		Dyn11	785	3750	3990	4280	1.0	
500	10	±5	0.4	Yyn0	930	4590	4880	5230	1.0	
630	10.5				1070	5530	5880	6290	0.85	
630	11				1040	5610	5960	6400	0.85	
800					1215	6550	6960	7460	0.85	
1000					1415	7650	8130	8760	0.85	
1250					1670	9100	9690	10370	0.85	
1600					1960	11050	11730	12580	0.85	
2000					2440	13600	14450	15560	0.7	
2500					2880	16150	17170	18450	0.7	

Note: The load losses listed in the table are the values of different insulation systems at the reference temperature (specified in GB/T1094.11) in parentheses. The loads under other insulation systems not included in the table need to be converted based on their respective reference temperatures, using the insulation system temperature data of "155 °C (F)" as a reference.

### 3.4 SC(B)14 series level 2 energy consumption 6kV、10kV level non excited voltage regulation distribution dry-type transformer

Rated Capacity (kVA)	Rated voltage and tap range			Connecting groups	No-load loss	Load Loss W			No-load current %	Impedance Voltage %
	HV	Tap range	LV			130°C(B) 100°C	155°C(F) 120°C	180°C(H) 145°C		
30					130	605	640	685	2.0	4.0
50					185	845	900	965	2.0	
80					250	1160	1240	1330	1.5	
100					270	1330	1415	1520	1.5	
125					320	1565	1665	1780	1.3	
160					365	1800	1915	2050	1.3	
200					420	2135	2275	2440	1.1	
250	6				490	2330	2485	2665	1.1	
315	6.3				600	2945	3125	3355	1.0	
400	6.6	±2×2.5		Dyn11	665	3375	3590	3850	1.0	
500	10	±5	0.4	Yyn0	790	4130	4390	4705	1.0	
630	10.5				910	4975	5290	5660	0.85	
630	11				885	5050	5365	5760	0.85	
800					1035	5895	6265	6715	0.85	
1000					1205	6885	7315	7885	0.85	
1250					1420	8190	8720	9335	0.85	
1600					1660	9945	10555	11320	0.85	
2000					2075	12240	13005	14005	0.7	
2500					2450	14535	15445	16605	0.7	

Note: ① The load losses listed in the table are the values of different insulation systems at the reference temperature (specified in GB/T1094.11) in parentheses. The load losses of other insulation systems not included in the table need to be converted based on their respective reference temperatures, using the data of "155 °C (F)" insulation system temperature as a reference.  
 ② The empty load losses listed in the table comply with the second level energy efficiency regulations in Table 2 of GB20052-2020

### 3.5 SC(B)18 series level 1 energy consumption 6kV、10kV level non excited voltage regulation distribution dry-type transformer

Rated Capacity (kVA)	Rated voltage and tap range			Connecting groups	No-load loss	Load Loss W			No-load current %	Impedance Voltage %
	HV	Tap range	LV			130°C(B) 100°C	155°C(F) 120°C	180°C(H) 145°C		
30				Dyn11 Yyn0	105	605	640	685	2.0	4.0
50					155	845	900	965	2.0	
80					210	1160	1240	1330	1.5	
100					230	1330	1415	1520	1.5	
125					270	1565	1665	1780	1.3	
160					310	1800	1915	2050	1.3	
200					360	2135	2275	2440	1.1	
250	6	±2×2.5 ±5	0.4		415	2330	2485	2665	1.1	
315	6.3				510	2945	3125	3355	1.0	
400	6.6				570	3375	3590	3850	1.0	
500	10				670	4130	4390	4705	1.0	
630	10.5				775	4975	5290	5660	0.85	
630	11				750	5050	5365	5760	0.85	
800					875	5895	6265	6715	0.85	
1000					1020	6885	7315	7885	0.85	
1250					1205	8190	8720	9335	0.85	
1600					1415	9945	10555	11320	0.85	
2000		1760	12240		13005	14005	0.7			
2500		2080	14535		15445	16605	0.7			
										6.0

Note: ①The load losses listed in the table are the values of different insulation systems at the reference temperature (specified in GB/T1094.11) in parentheses. The load losses of other insulation systems not included in the table need to be converted based on their respective reference temperatures, using the data of "155 °C (F)" insulation system temperature as a reference.

## 4. Outline dimension diagram

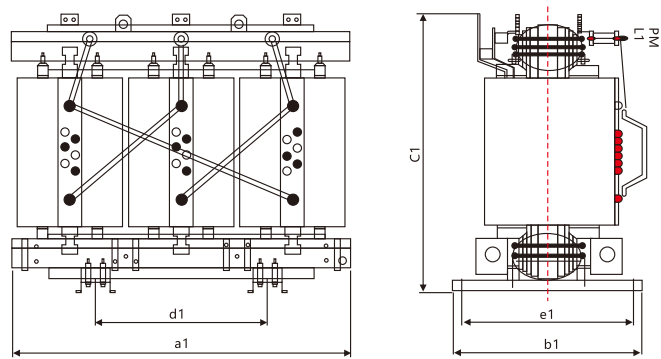

10KV distribution transformer outline dimension drawing

- Note: 1. High voltage output terminal Md. When the capacity SN<1600kVA, Md=M12; When SN ≥ 1600kVA, Md=M16  
 2. The transformer is a structure without a trolley.  
 If a trolley is required, the height will be increased by 100mm accordingly  
 3. The size of the forced air cooling system (fan) shall not exceed the range of the body size (a × b)

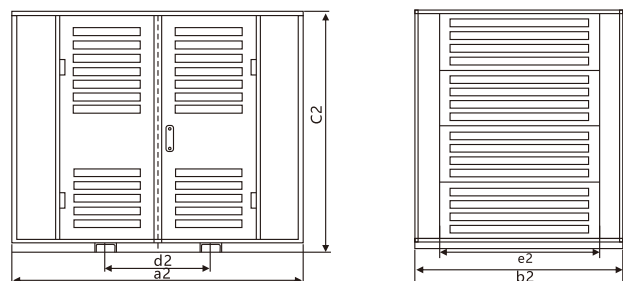

10KV Distribution Transformer IP20 with Shell Dimensional Drawing

- Note: 1. When the capacity SN is less than 2000kVA, Md=M12; When SN ≥ 2000kV, Md=M16.  
 2. The low-voltage terminal has an asymmetric structure,the figure contains parameters k1 and k2.

Rated capacity kV.A	External dimensions mm					Dimensions of the protective casing mm				
	a1	b1	c1	d1	e1	a2	b2	c2	d2	e2
10	600	400	520	350	400	900	900	1150	400	800
20	600	400	520	350	400	900	900	1150	400	800
30	600	400	620	400	350	1050	950	1200	400	850
50	630	450	660	400	350	1050	950	1200	400	850
63	780	500	765	400	400	1050	980	1300	400	880
80	780	500	765	400	400	1050	1000	1300	400	900
100	890	650	830	550	550	1200	1000	1300	550	900
125	910	650	850	550	550	1200	1000	1400	550	900
160	950	750	965	550	660	1250	1150	1450	550	1050
200	1000	750	1120	550	660	1300	1150	1500	550	1050
250	1040	750	1155	660	660	1400	1200	1550	660	1100
315	1080	750	1220	660	660	1400	1200	1650	660	1100
400	1105	750	1225	660	660	1500	1250	1800	660	1150
500	1150	900	1395	660	820	1550	1250	1800	660	1150
630	1340	900	1330	820	820	1700	1300	1700	820	1200
800	1400	900	1470	820	820	1750	1350	1850	820	1250
1000	1460	900	1475	820	820	1850	1400	1900	820	1300
1250	1485	900	1605	820	820	1850	1400	1950	820	1300
1600	1580	1050	1680	950	950	2000	1450	2050	950	1350
2000	1690	1050	1840	950	950	2050	1550	2150	950	1450
2500	1765	1050	1885	1070	950	2150	1600	2200	1070	1500
3150	1950	1170	1900	1070	1070	2350	1600	2250	1070	1500
4000	2030	1170	2000	1070	1070	2400	1600	2300	1070	1500

Note: ① Due to continuous product improvement, the size may change. The size information provided in this sample is for reference only. If you have any questions, please contact our company;

② Special sizes can be customized;

③ The dimensions of transformers with a capacity of 200kVA and below are all without fans.

## 5. Low voltage terminal diagram

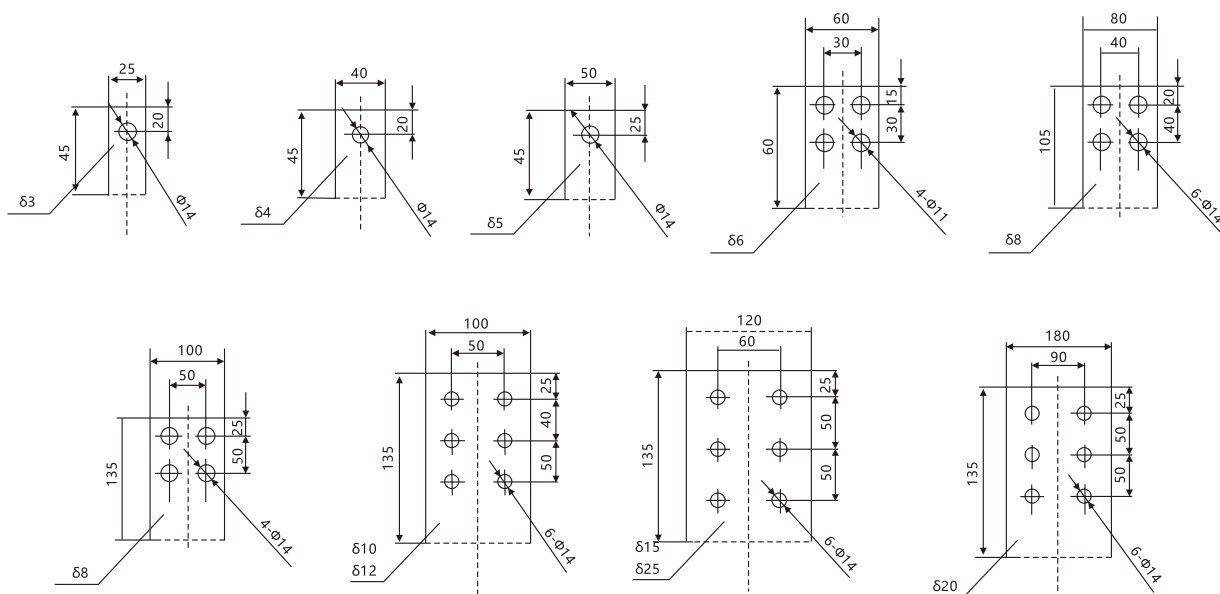

### ■ 20kV SCB series resin insulated dry-type transformer

#### 1.1 SC(B)10 series 20kV level non excited voltage regulation distribution dry-type transformer

Rated Capacity (kVA)	Rated voltage and tap range			Connecting groups	No-load loss	Load Loss W			No-load current %	Impedance Voltage %	
	HV	Tap range	LV			130°C(B) 100°C	155°C(F) 120°C	180°C(H) 145°C			
50	20	±2×2.5 ±5	0.4	Dyn11 Yyn0	340	1160	1230	1310	2.0	6.0	
100					540	1870	1990	2130	1.8		
160					670	2330	2470	2640	1.5		
200					730	2770	2940	3140	1.5		
250					840	3220	3420	3660	1.3		
315					910	3850	4080	4360	1.3		
400					22	1150	4650	4840	5180		1.1
500					24	1350	5460	5790	6190		1.1
630					1530	6450	6840	7320	1.0		
800					1750	7790	8260	8840	1.0		
1000					2070	9220	9780	10400	0.85		
1250					2380	10800	11500	12300	0.85		
1600					2790	13000	13800	14800	0.85		
2000					3240	15400	16300	17500	0.7		
2500					3870	18200	19300	20700	0.7		
2000					3240	16800	17800	19100	0.7		
2500	3870	20000	21200	22700	0.7						

Note: ① The load losses listed in the table are the values of different insulation systems at the reference temperature (specified in GB/T1094.11) in parentheses. The load losses of other insulation systems not included in the table need to be converted based on their respective reference temperatures using the data of "155 °C (F)" insulation system temperature.  
 ② This table is applicable to transformers with dual voltage exchange of 20kV and 10kV.

#### 1.2 SC(B)12 series 20kV level non excited voltage regulation distribution dry-type transformer

Rated Capacity (kVA)	Rated voltage and tap range			Connecting groups	No-load loss	Load Loss W			No-load current %	Impedance Voltage %	
	HV	Tap range	LV			130°C(B) 100°C	155°C(F) 120°C	180°C(H) 145°C			
50	20	±2×2.5 ±5	0.4	Dyn11 Yyn0	340	1160	1230	1310	2.0	6.0	
100					540	1870	1990	2130	1.8		
160					670	2330	2470	2640	1.5		
200					730	2770	2940	3140	1.5		
250					840	3220	3420	3660	1.3		
315					910	3850	4080	4360	1.3		
400					22	1150	4650	4840	5180		1.1
500					24	1350	5460	5790	6190		1.1
630					1530	6450	6840	7320	1.0		
800					1750	7790	8260	8840	1.0		
1000					2070	9220	9780	10400	0.85		
1250					2380	10800	11500	12300	0.85		
1600					2790	13000	13800	14800	0.85		
2000					3240	15400	16300	17500	0.7		
2500					3870	18200	19300	20700	0.7		
2000					3240	16800	17800	19100	0.7		
2500	3870	20000	21200	22700	0.7						

Note: ① The load losses listed in the table are the values of different insulation systems at the reference temperature (specified in GB/T1094.11) in parentheses, and the negative losses of other insulation systems not included in the table. The load loss needs to be converted based on the data of the insulation system temperature of "155 °C (F)" according to their respective reference temperatures.  
 ② This table is applicable to transformers with dual voltage exchange of 20kV and 10kV.

### ■ 35kV SCB series resin insulated dry-type transformer

#### 1.1 35kV level non excited voltage regulation distribution dry-type transformer

Rated Capacity (kVA)	Rated voltage and tap range			Connecting groups	No-load loss	Load Loss W			No-load current %	Impedance Voltage %
	HV	Tap range	LV			130°C(B) 100°C	155°C(F) 120°C	180°C(H) 145°C		
50	35 ~ 38.5	±2×2.5 ±5	0.4	Dyn11 Yyn0	450	1340	1420	1520	2.3	6.0
100					630	1970	2090	2230	2.0	
160					790	2650	2810	3000	1.5	
200					880	3130	3320	3550	1.5	
250					990	3580	3800	4060	1.3	
315					1170	4250	4510	4820	1.3	
400					1370	5100	5410	5790	1.1	
500					1520	5270	6650	7110	1.1	
630					1860	7250	7690	8230	1.0	
800					2160	8500	9120	9760	1.0	
1000					2430	9860	10400	11100	0.75	
1250					2830	12000	12700	13600	0.75	
1600					3240	14600	15400	16500	0.75	
2000					3820	17200	18200	19500	0.75	
2500					4450	20600	21800	23300	0.75	

#### 1.2 Technical parameters of 35kV non excited voltage regulating power transformer

Rated Capacity (kVA)	Rated voltage and tap range			Connecting groups	No-load loss	Load Loss W			No-load current %	Impedance Voltage %
	HV	Tap range	LV			130°C(B) 100°C	155°C(F) 120°C	180°C(H) 145°C		
800	35 ~ 38.5	±2×2.5 ±5	3.15 6 6.3 10 10.5 11	Dyn11 Yd11 Yyn0	2250	8870	9400	10000	0.95	6.0
1000					2670	10300	10900	11600	0.95	
1250					3130	12100	12900	13800	0.85	
1600					3690	14600	15400	16500	0.85	7.0
2000					4230	17200	18200	19500	0.75	
2500					4860	20600	21800	23300	0.75	8.0
3150					6030	23100	24500	26200	0.70	
4000					7020	27700	29400	31500	0.70	
5000					8370	32900	34900	37400	0.60	
6300					9900	38500	40800	43700	0.60	9.0
8000			11300	43400	46000	49300	0.50			
10000			12900	52400	55500	59400	0.50			
12500			15700	60900	64600	69100	0.40			
16000			19300	71700	75000	81300	0.40			
20000			22900	80600	85500	91500	0.35	10.0		

#### 1.3 35kV on load voltage regulating power transformer

Rated Capacity (kVA)	Rated voltage and tap range			Connecting groups	No-load loss	Load Loss W			No-load current %	Impedance Voltage %
	HV	Tap range	LV			130°C(B) 100°C	155°C(F) 120°C	180°C(H) 145°C		
2000	35 ~ 38.5	±4×2.5	6 6.3 10 10.5 11	Dyn11 Yd11	4500	17900	19000	20300	0.75	7.0
2500					5220	21300	22600	24200	0.75	
3150					6300	24000	25400	27200	0.70	
4000					7380	28700	30400	32600	0.70	8.0
5000					8730	34000	36100	38600	0.60	
6300					10800	39400	41800	44700	0.60	9.0
8000					11800	44800	47500	50800	0.5	
10000					13500	53900	57100	61200	0.5	
12500					16100	62700	66500	71100	0.4	10.0
16000					20200	73800	78200	83700	0.4	
20000	23800	83000	88000	94200	0.35					

# EXPORT CUSTOMIZED TRANSFORMER



## ■ SINGLE PHASE OVERHEAD TRANSFORMER

### 1、 Product overview

---

ANDELI supplies transformers on the power column. Including single-phase and three-phase column mounted transformers. It can reduce the length of low-voltage distribution lines, lower line losses, and improve power supply quality. The transformer adopts an efficient and energy-saving coil core structure design. The characteristics of this transformer are small size, low infrastructure investment, reduced low-voltage power supply radius, and low-voltage line loss of over 60%. Adopting a fully sealed structure with strong overload capacity, high reliability for continuous operation, and simple maintenance. Suitable for rural power grids, remote mountainous areas, and dispersed village energy transformation. Our transformer adopts technological design, using high-quality materials and components, with reliable quality and long operating time.

### 2、 Transformer Model Description

---



### 3. Features

1. All units are built in accordance with both ANSI C57 12.00 and ANSI C57 12.20, except as modified to comply with customer specifications.
2. Mild steel tank with welded lifting lugs and hanger brackets for direct to pole mounting.
3. Single piece clamped cover band meets cover retention requirements of ANSI standards.
4. Electrostatically applied polyester powder paint
5. System for superior corrosion protection.
6. HV porcelain cover mounted bushings
7. Tank wall mounted porcelain or polymer low voltage bushings.
8. Tin-plated bronze terminals for connection to copper or aluminum.
9. Insulated cover for wildlife protection.
10. Laser engraved aluminum nameplate.
11. NON-PCB insulating oil.

### 5. Technical data

Rated Capacity (kVA)	Primary rating(V)	Tapping Range(%)	Secondary Rating (V)	Loss(W)	
				No load	loss Load loss
3	34500/19920	±2x2.5% ±1 x 5% Or others	120-240 110-220 240-480 250-500 Or others	12	45
5				25	75
10				50	120
15				65	195
25				105	290
37.5				140	360
50				180	500
75				250	650
100				275	850
167				455	1410
250	650	2000			
333	845	2500			

Note: \*The above parameter is only subject to our standard design, special requirement can be customized

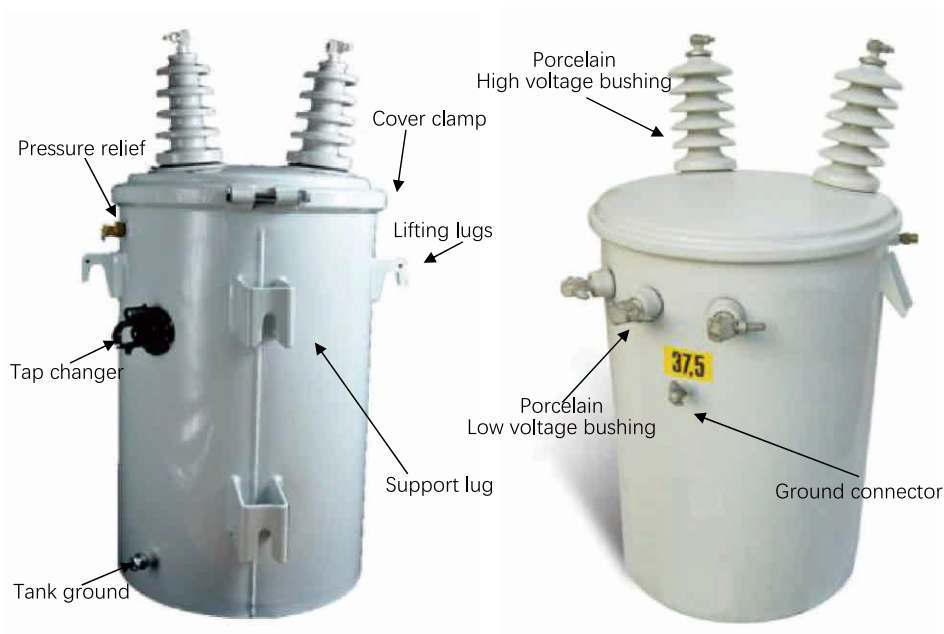

### Overall and mounting dimensions(mm)

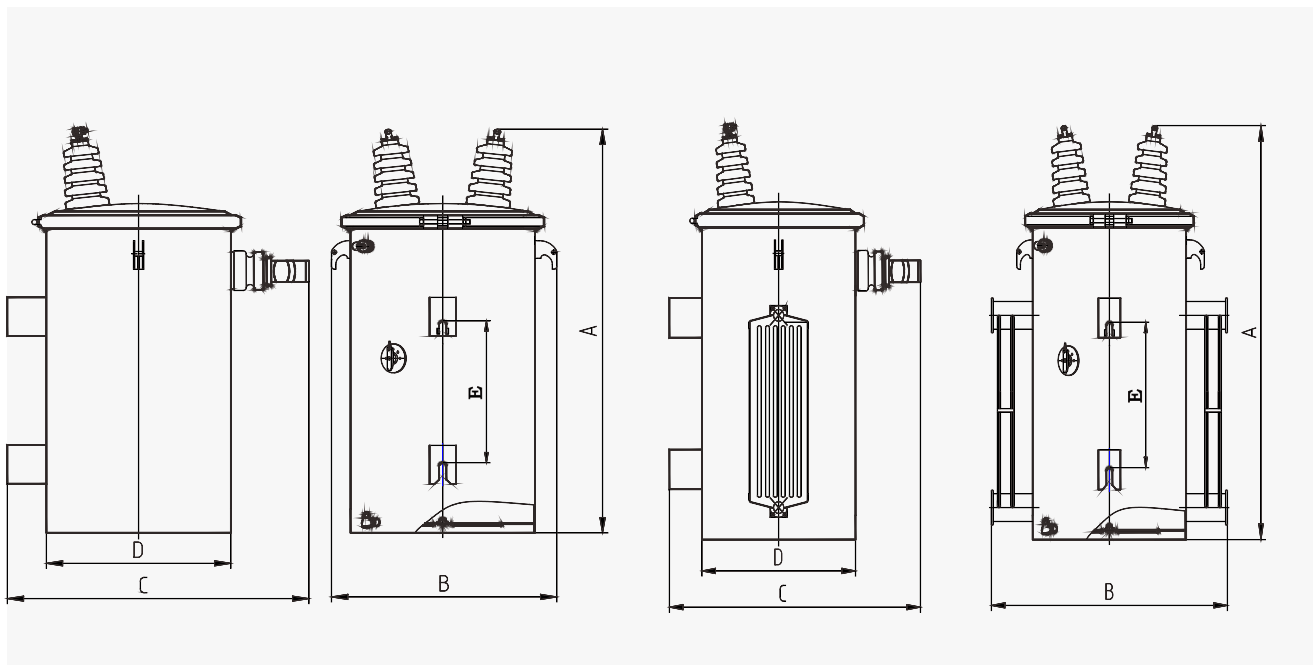

Rated Capacity (kVA)	Overall size(mm)					Weight(kgs)	
	A	B	C	D	E	Oil weight	Total weight
3	760	430	530	330	286	20	105
5	780	430	530	330		30	110
10	830	430	530	330		30	130
15	850	480	580	380		40	185
25	880	500	580	410		45	210
37.5	930	560	640	460		60	300
50	980	560	640	460		70	335
75	980	680	720	554	591	103	460
100	1020	780	800	610		123	530
167	1050	830	890	660		155	670
250	1100	960	950	660		247	950
333	1150	960	960	660		250	1000



