

ANDELI

ANDELI GROUP CO.,LTD.

Add: No.208,Weiqi Road,Yueqing Economic Development Zone,
Yueqing,Zhejiang,China

Tel: 0086-577-6273 1666

Fax: 0086-577-6273 1777

E-mail: andeli@andeligroup.com

[Http://www.andeligroup.com](http://www.andeligroup.com)

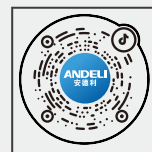

ANDELI



**HV & LV
COMPLETE EQUIPMENT**

ANDELI GROUP CO.,LTD.



Brief Introduction

www.andeligroup.com

Andeli Group is a professional manufacturer with electrical as its core industry, integrating research and development, production, sales, and service. The company has been awarded multiple honors, including Top 10 Growth Enterprises in China's Electrical Industry, National Customer Satisfaction Enterprise, National High tech Enterprise, National Ministry of Industry and Information Technology Green Factory, National Specialized and Innovative Small Giant Enterprise, and National Ministry of Industry and Information Technology Green Supply Chain Management Enterprise.

Andeli Group adheres to the mission of providing customers with satisfactory power products and solutions. We mainly research and develop complete sets of transmission and distribution equipment, power transformers, high and low voltage electrical components, instruments and meters, welding equipment, new energy and other series. The product is widely used in many fields such as State Grid, Southern Power Grid, Inner Mongolia Power Grid and rail transit, commercial housing, energy and chemical industry, metal smelting, and power management. Andeli actively implements a globalization strategy and has established branch offices in the United Arab Emirates, Russia, Brazil, Pakistan, Thailand, Saudi Arabia, and other places. Its products are exported to more than 100 countries and regions around the world.

Andeli people, who uphold the principles of honesty and diligence in their work, sincerely work hand in hand with elites from all walks of life to create a better future together.



AXHW-12

Combined Primary-Secondary RMU
Environmentally friendly gas

Model Meaning

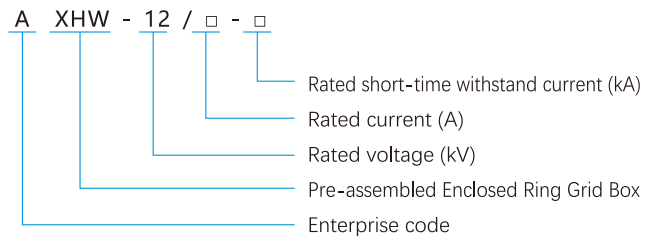

Product Overview and Features

Pre-assembled closed ring network box is mainly used in 10kV cable ring network power supply or terminal power supply system for receiving and distributing electric energy. This product is equipped with AHN-12 series environmental protection gas insulated ring network cabinet produced by our company, which has the functions of fully insulated, fully sealed, dustproof, corrosion-resistant, maintenance-free, etc., and can realize the combination of different programs. Satisfy all kinds of knotting methods. The ring network cabinet in the ring network box can also be combined with 10kV power supply PT, distributed power module, DTU, communication and control terminals to realize the automation of medium-voltage distribution network, which greatly improves the reliability of urban power supply and distribution network. Its simple, convenient, flexible connection combination, economic, reliable, durable structure characteristics, become the first choice of equipment for distribution network cable project.

Pre-assembled closed ring box can be placed on both sides of the street, residential neighborhoods, urban green belts and other concentrated power areas.

Main technical parameters

| Name | | Load switch | | Combined electrics | | Circuit breaker | |
|--|----------------------|-------------|---------|--------------------|--|-----------------|---------|
| Rated voltage | | 12kV | | 12kV | | 12kV | |
| Rated frequency | | 50Hz | | 50Hz | | 50Hz | |
| Rated current. | | 630A | | 125A | | 630A | |
| Rated frequency withstand voltage | Interphase, Relative | 42kV | | 42kV | | 42kV | |
| | Isolated Break | 48kV | | 48kV | | 48kV | |
| Rated lightning impulse withstand voltage | Interphase, Relative | 75kV | | 75kV | | 75kV | |
| | Isolated Break | 85kV | | 85kV | | 85kV | |
| Rated short-time withstand current | | 20kA/4s | 25kA/4s | - | | 20kA/4s | 25kA/4s |
| Rated peak withstand current | | 50kA | 63kA | - | | 50kA | 63kA |
| Rated short-circuit breaking current | | - | | 31.5kA | | 20kA | 25kA |
| Rated short-circuit closing current | | 50kA | 63kA | 80kA | | 50kA | 63kA |
| Rated transfer current | | - | | 1600A | | - | |
| Rated active load breaking current | | 630A | | - | | 630A | |
| Rated cable charging and breaking current | | 10A | | - | | - | |
| Annual leakage rate for environmentally friendly gases | | | | ≤0.01% | | | |
| Enclosure protection grade | | | | IP44 W | | | |



■ AXTW-12

Combined Primary-Secondary RMU
Solid Insulation

Model Meaning

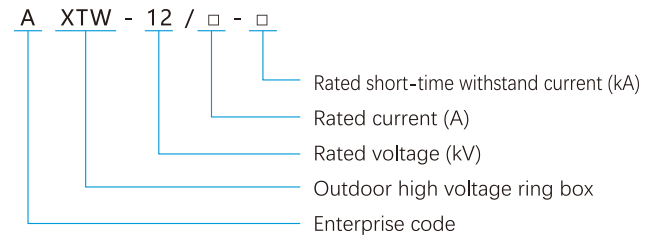

Product Overview and Features

Outdoor high-voltage ring net cages are mainly used in 10kV cable ring network power supply or terminal power supply systems for receiving and distributing electrical energy. This product is equipped with the AGN-12 series solid insulated ring main unit produced by our company, which has functions such as full insulation, full sealing, dust prevention, corrosion resistance, and maintenance free, and can achieve different solutions Satisfy various wiring methods. The ring main unit in the switching station can also be connected to 10KV power supply, distributed power supply modules DTU、 The combination of communication control terminals to achieve automation of medium voltage distribution networks greatly improves the reliability of urban power supply and distribution networks. Its simple, convenient, and flexible connection combination method, as well as its economical, reliable, and durable structural characteristics, have become the preferred equipment for distribution network cable engineering.

Outdoor high-voltage ring net cages can be placed on both sides of streets, residential areas, urban green belts, and other centralized power consumption areas.

Main technical parameters

| Name | Load switch | | Combined electrics | Circuit breaker | |
|---|----------------------|---------|--------------------|-----------------|---------|
| Rated voltage | 12kV | | 12kV | 12kV | |
| Rated frequency | 50Hz | | 50Hz | 50Hz | |
| Rated current. | 630A | | 125A | 630A | |
| Rated frequency withstand voltage | Interphase, Relative | 42kV | 42kV | 42kV | |
| | Isolated Break | 48kV | 48kV | 48kV | |
| Rated lightning impulse withstand voltage | Interphase, Relative | 75kV | 75kV | 75kV | |
| | Isolated Break | 85kV | 85kV | 85kV | |
| Rated short-time withstand current | 20kA/4s | 25kA/4s | - | 20kA/4s | 25kA/4s |
| Rated peak withstand current | 50kA | 63kA | - | 50kA | 63kA |
| Rated short-circuit breaking current | - | | 31.5kA | 20kA | 25kA |
| Rated short-circuit closing current | 50kA | | 50kA | 50kA | 63kA |
| Rated transfer current | - | | 2000A | - | |
| Rated active load breaking current | 630A | | - | 630A | |
| Rated cable charging and breaking current | 10A | | - | - | |
| Enclosure protection grade | | | IP44 | | |



AXBW-12

Combined Primary-Secondary RMU
SF6 gas

Model Meaning

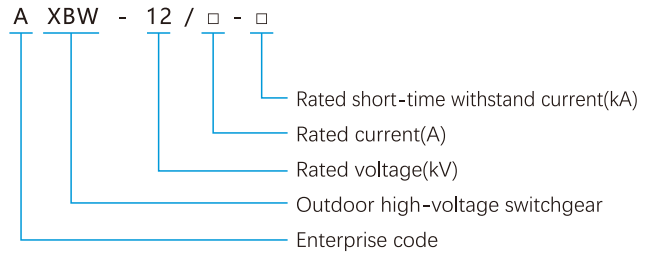

Product Overview and Features

Outdoor high-voltage switchgear is mainly used in 10kV cable ring network power supply or terminal power supply systems for receiving and distributing electrical energy. This product is equipped with our company's AQGN mouth-12 series SF6 gas insulated ring main unit, which has functions such as full insulation, full sealing, dust prevention, corrosion resistance, and maintenance free. It can achieve different combinations of solutions to meet various wiring methods. The ring main unit in the switching station can also be connected to 10kV power PT, distributed power modules DTU. The combination of communication control terminals to achieve automation of medium voltage distribution networks greatly improves the reliability of urban power supply and distribution networks. Its simple, convenient, and flexible connection combination method, as well as its economical, reliable, and durable structural characteristics, have become the preferred equipment for distribution network cable engineering.

Outdoor high-voltage switchgear can be placed on both sides of streets, residential areas, urban green belts, and other centralized power consumption areas.

Main technical parameters

| Name | | Load switch | | Combined electrics | | Circuit breaker | |
|---|----------------------|-------------|---------|--------------------|--|-----------------|---------|
| Rated voltage | | 12kV | | 12kV | | 12kV | |
| Rated frequency | | 50Hz | | 50Hz | | 50Hz | |
| Rated current. | | 630A | | 125A | | 630A | |
| Rated frequency withstand voltage | Interphase, Relative | 42kV | | 42kV | | 42kV | |
| | Isolated Break | 48kV | | 48kV | | 48kV | |
| Rated lightning impulse withstand voltage | Interphase, Relative | 75kV | | 75kV | | 75kV | |
| | Isolated Break | 85kV | | 85kV | | 85kV | |
| Rated short-time withstand current | | 20kA/4s | 25kA/4s | - | | 20kA/4s | 25kA/4s |
| Rated peak withstand current | | 50kA | 63kA | - | | 50kA | 63kA |
| Rated short-circuit breaking current | | - | | 31.5kA | | 20kA | 25kA |
| Rated short-circuit closing current | | 50kA | 63kA | 80kA | | 50kA | 63kA |
| Rated transfer current | | - | | 1600A | | - | |
| Rated active load breaking current | | 630A | | - | | 630A | |
| Rated cable charging and breaking current | | 10A | | - | | - | |
| Annual SF6 gas leakage rate | | | | ≤0.01% | | | |
| Enclosure protection grade | | | | IP44 | | | |



DFW series

HV Cable Distribution Cabinet

Model Meaning

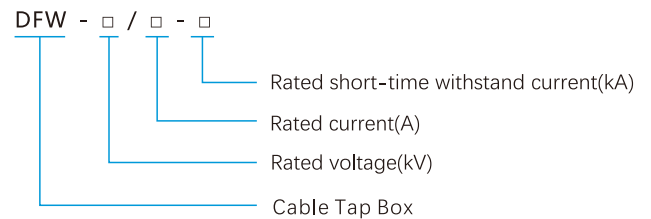

Product Overview and Features

In the power system 10KV distribution network cable chemical engineering, how an economic, reliable, easy to maintain the wiring alternative to the original distribution network overhead line in a large number of branches become - a big problem, and the emergence of the cable branch box completely solved the problem, and with its insulated, fully sealed characteristics and make the line failure rate greatly reduced, become the first choice of equipment for distribution network cable engineering. Its simple, convenient, flexible connection combination, so that it can replace the ring network cabinet in some occasions; necessary occasions, can be buried in the ground or immersed in water, saving the investment in equipment and cables, and improve the reliability of power supply, widely used in commercial centers, industrial parks and urban densely populated areas. Cable junction box can be divided into American cable branch box, European cable branch box and cable branch box with switch and so on according to the different structural forms and cable head types.

Main technical parameters

| Technical Parameters | 200A circuit parameter | 600A circuit parameter |
|-------------------------------------|------------------------|------------------------|
| Rated Voltage | 1 5KV | 1 5KV |
| Maximum phase-to-phase voltage | 14. 4KV | 14. 4KV |
| Maximum phase-to-ground voltage | 8.3KV | 8.3KV |
| 1 minute frequency voltage | 42KV | 42KV |
| 15 minutes DC withstand voltage | 52KV | 52KV |
| Lightning impulse withstand voltage | 75KV | 75KV |
| Minimum corona onset voltage | 11KV | 11KV |
| Rated current | 200A | 600A |
| Rated thermal stability current | 3.5KA/3S | 20KA/2S |
| Rated dynamic stabilizing current | 10KA/0.2S | 50KA/0.3S |
| Partial discharge | ≤10PC/15KV | ≤10PC/15KV |
| Circuit resistance | ≤40μ Q | ≤40μ Q |
| Protection Rating | IP33 | IP33 |



■ ANHN-12 Eco-Friendly Medium-Voltage RMU

Model Meaning

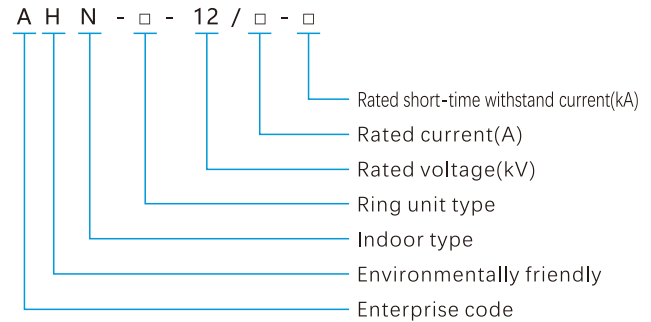

Product Overview and Features

AHN-12 environmentally friendly medium voltage ring network switchgear is a new type of green metal-enclosed switchgear, the materials used in the manufacture of the product are all non-toxic and harmless substances, the use of nitrogen or dry air as an insulating medium reduces the emission of greenhouse effect gases to achieve the purpose of environmental protection, and will not discharge any poisonous and harmful substances in use, and the materials can be recycled again after the life cycle, which determines the use of the Environmental protection. The environmentally friendly gas insulated ring network cabinet is suitable for industrial and civil cable ring network and distribution network terminal project.

Areas of application and environments of use

As the acceptance and distribution of electric energy, it is especially suitable for power distribution in urban residential areas, small secondary substations, open and close houses, cable branch boxes, box-type substations, industrial and mining enterprises, shopping malls, airports, subways, wind power generation, stadiums, railroads, tunnels and other places to use.

Ambient temperature: Upper limit +55C, Lower limit -40C.

Altitude: No more than 3000m;

Relative humidity: Daily average value ≤95%, Monthly average value ≤90%.

Water vapor pressure: Daily average value ≤2.2kPa; Monthly average value ≤1.8kPa.

Workplace: The surrounding air is not obviously subject to dust, smoke, corrosive and/or combustible gases, vapors or salt spray pollution;
No fire house explosion, serious filth, serious chemical corrosion and severe vibration.

The amplitude of electromagnetic interference induced in the secondary system ≤ 1.6kV.

Note: Altitude greater than 3000m or special use conditions require customized product solutions.

Main technical parameters

| Name | Unit | Load switch | Circuit breaker |
|---|--------|---------------------|---------------------|
| Ring Network Cabinet Technical Parameters | | | |
| Rated Voltage | KV | 12 | 12 |
| Rated current | A | 630 | 630 |
| Rated Frequency | Hz | 50 | 50 |
| Rated short-circuit breaking current | KA | 25 | 25 |
| Rated closing current (peak) | KA | 63 | 63 |
| Rated short-time frequency withstand voltage (phase-to-phase, relative ground/outlet) | KV | 42/48 | 42/48 |
| Rated lightning impulse withstand voltage (phase-to-phase, relative ground/outlet) | KV | 75/85 | 75/85 |
| Rated operation program | | O-0.3S-CO-180S-CO | / |
| Rated short-time withstand current/duration | KA/S | 25/4s | 25/4s |
| Rated peak withstand current | KA | 63 | 63 |
| Rated active load breaking current ¹ Rated closed loop breaking current | A | / | 630 |
| Rated cable charging breaking current (CC2) | A | 25 | 25 |
| 5% rated active load current | A | / | 31.5 |
| Main circuit resistance | μQ | ≤140 | ≤140 |
| Mechanical life (circuit breaker, load switch/isolation/earthing) | 次 | 20000/5000/3000 | 10000/5000/3000 |
| Insulation Gas | | Nitrogen or dry air | Nitrogen or dry air |
| Annual air leakage rate | %/year | ≤0.01 | ≤0.01 |
| Rated filling pressure (abs20°C) | Mpa | 0.02 | 0.02 |
| Protection class (cabinet/gas box) | | IP41/IP67 | IP41/IP67 |
| Dimension(WxDxH) | mm | 420x850x2000 | 420x850x2000 |
| Switching Mechanical Characteristics | | | |
| Rated Current | A | 630 | 630 |
| Rated short-circuit breaking current | KA | 25 | 25 |
| Contact opening distance | mm | 9±1 | 9±1 |
| Contact overtravel | mm | 3.5±0.5 | 2.5±0.5 |
| Rated contact pressure | N | 1640±160 | 740±160 |
| Contact closing bounce time | ms | ≤2ms | ≤2ms |
| Closing and breaking non-simultaneity | ms | ≤2ms | ≤2ms |
| Average opening speed | m/s | 1.1±0.2 | 1.1±0.2 |
| Average closing speed | m/s | 0.6±0.2 | 0.6±0.2 |
| Closing time | ms | ≤80 | ≤80 |
| Breaking time | ms | ≤50 | ≤50 |



AGN-12 series Solid-Insulated RMU

Model Meaning

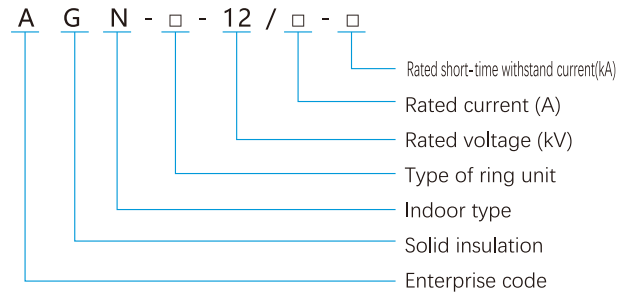

Product Overview and Features

Our company independently developed the solid-insulated ring main unit switchgear, a new generation of environmentally friendly composite-insulated ring main unit. The product consists of three basic modular units: V-unit (circuit breaker), C-unit (load switch), and F-unit (combination appliance). Each unit can be used independently or flexibly expanded.

The equipment structure is divided into an intelligent control instrument compartment, an operating mechanism, and a primary section. The instrument compartment can be equipped with a microcomputer protection controller; the primary section adopts the APG (Automatic Pressure Gelation) process, which fully encapsulates the disconnecter and arc extinguishing chamber in epoxy resin and connects to the busbar via dedicated terminals.

The arc extinguishing chamber utilizes copper-chromium contact material, an R-type longitudinal magnetic field contact, and a one-step sealing and exhausting process. Compared to previous designs using copper-aluminum contacts and cup-shaped longitudinal magnetic field structures with incomplete sealing, it shows significant improvements in interrupting capacity, electrical lifespan, stability, temperature rise control, and insulation level.

The operating mechanism employs an integrated spring-operated mechanism combined with the switch. The disconnecter and main switch mechanisms are unified, featuring a simple structure, fewer transmission parts, and high reliability. It supports both manual and motorized operation and facilitates interlocking functions. This equipment is fully insulated and sealed. The main conductive circuits, including the vacuum arc extinguishing chamber, disconnecter, grounding switch, and main/branch busbars, are encapsulated as expandable modules using solid insulating material. The surface of these modules is coated with a reliably grounded conductive or semi-conductive shielding layer, ensuring safety for personnel when touching accessible parts.

Main technical parameters

| Name | | Unit | Load switch | Combined electrics | Circuit breaker |
|--------------------------------------|--|------|-------------|--------------------------------|-----------------|
| Rated voltage | | kV | 12 | 12 | 12 |
| Rated frequency | | Hz | 50 | 50 | 50 |
| Rated current | | A | 630 | Depends on fuse current rating | 630 |
| Rated insulation level | Frequency withstand voltage (phase-to-phase and phase-to-ground) | kV | 42 | 42 | 42 |
| | Frequency Withstand Voltage (isolation) | kV | 48 | 48 | 48 |
| | Industrial frequency withstand voltage (control and auxiliary circuits) | kV | 2 | 2 | 2 |
| | Lightning impulse withstand voltage (phase-to-phase and phase-to-ground) | kV | 75 | 75 | 75 |
| | Lightning Impulse Withstand Voltage (isolated circuit) | kV | 85 | 85 | 85 |
| Rated short-time withstand current | | kA | 25 | - | 25 |
| Rated peak withstand current | | kA | 63 | - | 63 |
| Rated short-circuit closing current | | kA | 63 | Limited by high voltage fuses | 63 |
| Rated short-circuit breaking current | | kA | - | Limited by high voltage fuses | 25 |
| Rated transfer current | | A | - | 3150 | - |
| Rated active load breaking current | | A | 630 | - | - |
| Rated closed loop breaking current | | A | 630 | - | 630 |
| Mechanical life | Load switches/circuit breakers | time | 5000 | 5000 | 10000 |
| | Disconnect/Earth Switch | time | 3000 | 3000 | 3000 |
| Main circuit resistance | | μQ | ≤150 | ≤300 | ≤150 |



AQGN-12 Fully Insulated Sealed RMU

Model Meaning

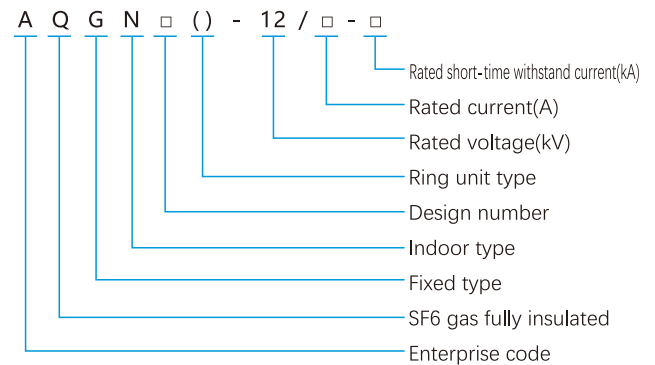

Product Overview and Features

AQGND-12 type gas-insulated SF6 metal-enclosed fully insulated ring main unit switchgear is independently developed and manufactured by our company. It is suitable for 10KV power distribution systems and serves as an ideal switching solution for various urban and rural substation and power distribution applications.

Featuring a modular design, the product includes two main categories: fixed unit combinations and expandable units. Its compact and flexible structure meets diverse requirements of different substations. All live parts and switches are sealed inside a stainless steel enclosure with SF6 gas insulation, ensuring high reliability, strong environmental adaptability, and maintenance-free operation, thereby effectively guaranteeing operational safety and personnel protection.

Main technical parameters

| Name | Unit | Load switch | Combined electrics | Circuit breaker | |
|--|--------------------------------|-------------|--------------------|-----------------|-------|
| Rated voltage | kV | 12 | 12 | 12 | |
| Rated frequency | Hz | 50 | 50 | 50 | |
| Rated current | A | 630 | 125 | 630 | |
| 1min frequency withstand voltage | Interphase, Relatively | kV | 42 | 42 | |
| | Isolated breaks | kV | 48 | 48 | |
| Lightning impact withstand voltage | Interphase, Relatively | kV | 75 | 75 | |
| | Isolated breaks | kV | 85 | 85 | |
| Frequency withstand voltage for auxiliary and control circuits | kV | 2 | 2 | 2 | |
| Rated short-time withstand current | kA | 25 | - | 25 | |
| Rated short circuit duration | s | 4 | - | 4 | |
| Rated peak withstand current | kA | 63 | - | 63 | |
| Rated short-circuit breaking current | kA | - | 31.5 | 25 | |
| Rated short-circuit closing current | kA | 63 | 80 | 63 | |
| Rated transfer current | A | - | 1600 | - | |
| Rated active load breaking current | A | 630 | - | 630 | |
| Rated closed loop breaking current | A | 630 | - | 630 | |
| Rated cable charging and breaking current | A | 10 | - | 15 | |
| Mechanical life | Load switches/Circuit breakers | time | 5000 | 5000 | 10000 |
| | Disconnectors/Earth switches | time | 3000 | 3000 | 3000 |
| Circuit resistance | v Ω | ≤150 | ≤400 | ≤150 | |
| Rated inflation pressure | bar | 1.35 | | | |
| Annual SF6 gas leakage rate | %/year | ≤0.01 | | | |
| Protection class | Gas tank IP67, Cabinet IP4X | | | | |



■ KYN61-40.5 (Z) type High-Voltage Armored Withdrawable Metal-Enclosed Switchgear

Model Meaning

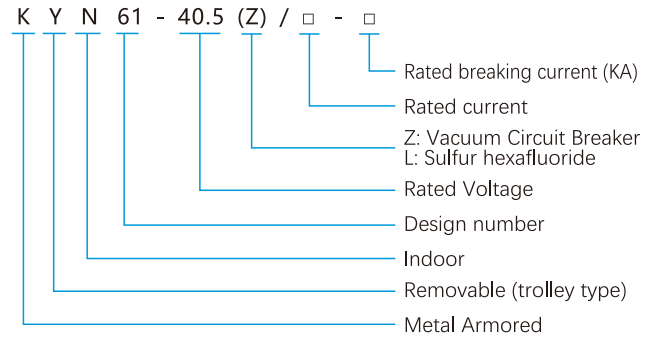

Product Overview and Features

Armored move-open metal-enclosed switchgear (hereinafter referred to as "switchgear") which is suitable for three-phase AC 50Hz power system, used for power plants, substations and industrial and mining enterprises in the distribution room to accept and distribute electricity, and the circuit control, protection and monitoring.

The product complies with the standards: GB/T3906 "3 ~ 35kV AC metal-enclosed switchgear", GB/T11022 "High-voltage switchgear and control equipment standard common technical requirements", IEC60298 "rated voltage of more than 1kV and 50kV below AC metal-enclosed switchgear and control equipment".

Main technical parameters

| Name | Unit | Parameters | |
|--|---|---------------------------------|-----------|
| KYN61-40.5 type switchgear rated parameters | | | |
| Rated Voltage | kV | 40.5 | |
| Rated current | A | 400, 630, 800, 1250, 1600, 2000 | |
| Rated short-circuit breaking current | kA | 25, 31.5 | |
| Rated short-time closing current | kA | 63, 80 | |
| Dynamic stabilizing current (peak) | kA | 63, 80 | |
| 4s thermal stabilizing current (rms) | kA | 25, 31.5 | |
| Rated insulation level | Lightning Impact Withstand Voltage | kV | 185 |
| | Main circuit 1min frequency withstand voltage | kV | 95 |
| Dimension(WxDxH) | | 1400x 2800x 2600 | |
| Protection level | Housing/Interior | mm | IP3X/IP2X |
| ZN85-40.5 vacuum circuit breaker rated parameters | | | |
| Rated Voltage | kV | 40.5 | |
| Rated current | A | 1250, 1600, 2000 | |
| Rated short-circuit breaking current | kA | 25, 31.5 | |
| Rated short-time closing current | kA | 63, 80 | |
| Dynamic stabilizing current (peak) | kA | 63, 80 | |
| 4s thermal stabilizing current (rms) | kA | 25, 31.5 | |
| Rated frequency | kV | 185 | |
| Rated insulation level | Lightning Impact Withstand Voltage | kV | 95 |
| | Main circuit 1min frequency withstand voltage | Hz | 50 |
| Rated sequence of operation | | 0-0.3s- CO-180s-CO | |
| Mechanical life | time | 10000 | |
| Closing time | ms | 50~ 100 | |
| Split time | ms | 35~ 60 | |



■ KYN28A-12(Z)(GZS1)type

Indoor Armored Withdrawable AC Metal-Enclosed Switchgear (Including Standardized Solutions)

Model Meaning

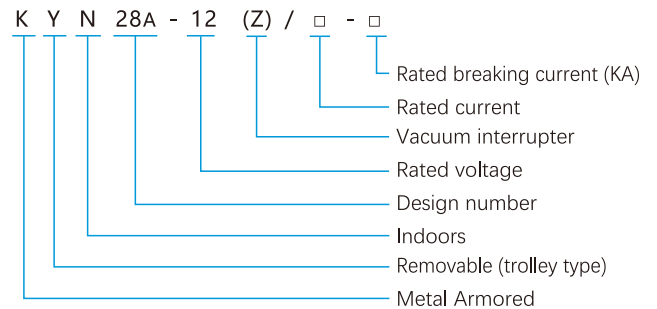

Product Overview and Features

Armored move-open type a.c. metal-enclosed switchgear (hereinafter referred to as "switchgear") is suitable for three-phase a.c. 50HZ power system, used for accepting and distributing electric energy, and controlling, protecting and monitoring the electric circuit.

This product conforms to the standards: GB/T3906 "3~35kV AC metal-enclosed switchgear", GB/T11022 "Standard Common Technical Requirements for High Voltage Switchgear and Control Equipment", IEC60298 "AC Metal-enclosed Switchgear and Control Equipment with Rated Voltage of 1kV and Above".

Main technical parameters

| Name | | Unit | Parameters | | |
|--|----------------------------------|------|---|-----|----|
| Switchgear technical parameters | | | | | |
| Rated insulation level | Rated voltage (V) | kV | 3.6 | 7.2 | 12 |
| | 1min frequency withstand voltage | kV | 24 | 32 | 42 |
| Lightning impulse withstand voltage (full wave) | | kV | 40 | 60 | 75 |
| Rated frequency | | Hz | 50 | | |
| Rated current | | A | 630,1250, 1600,2000,2500,3150,4000 | | |
| 4s short-time withstand current | | kA | 20,25,31.5,40,50 | | |
| Rated peak withstand current | | kV | 50, 63,80,100, 125 | | |
| Protection class | | | Enclosure IP4X, IP2X for each compartment panel | | |
| Vd4, VS1-12kV vacuum circuit breaker technical parameters | | | | | |
| Rated insulation level | Rated voltage (V) | kV | 3.6、7.2、12 | | |
| | 1min frequency withstand voltage | kV | 42 | | |
| Lightning impulse withstand voltage (full wave) | | kV | 75 | | |
| Rated frequency | | Hz | 50 | | |
| Rated current | | A | 630, 1250, 1600,2000,2500,3150,4000 | | |
| Rated short-circuit breaking current | | kA | 16,20,25,31.5, 40,50 | | |
| 4s short-time withstand current | | kV | 16,20,25,31.5, 40,50 | | |
| Rated peak withstand current | | kA | 40,50,63,80,100, 125 | | |
| Rated sequence of operation | | | Switch off-0.3S-Switch on-off180S-Switch on-off | | |
| Rated short-circuit breaking current ≥ 40kA sequence | | 次 | 50 | | |



■ HXGN□-12 type Indoor HV Vacuum RMU

Model Meaning

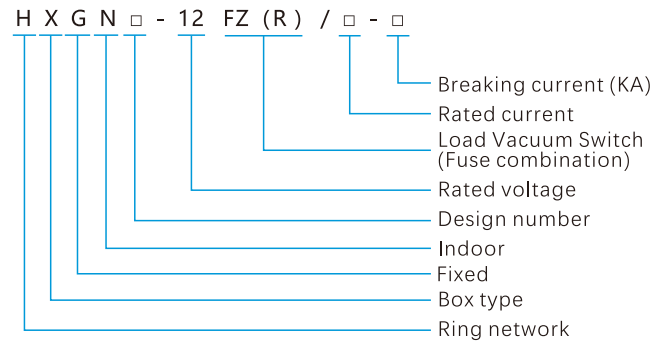

Product Overview and Features

Box-type (fixed) metal-enclosed ring network switchgear (referred to as ring network cabinet) is a new type of high-voltage switchgear produced for the needs of urban power grid renovation and construction. In the power supply system as the opening and closing load current as well as closing short circuit current, this ring network cabinet with vacuum load switch, the operating mechanism for the spring actuator, the mechanism can be manually operated, can also be electrically operated. The switch and disconnecting knife are equipped with manual operating mechanism.

The ring main unit is a complete set of strong, small size, no fire and explosion hazards, with reliable "five-proof" function.

Main technical parameters

| Name | Unit | Parameters | |
|--|--|------------|-------------|
| Rated Voltage/Maximum Operating Voltage | KV | 10/12 | |
| Rated current | A | 630 | |
| Main busbar current | Inlet Cabinet | A | 630 |
| | Outlet cabinet | A | 125 |
| Rated short-time withstand current | KA | 20 | |
| Rated short circuit duration | S | 4 | |
| Rated peak withstand current | KA | 50 | |
| Rated short-circuit closing current | KA | 50 | |
| Rated active load breaking current | A | 630 | |
| Closed non-breaking current | A | 630 | |
| Rated cable charging current | KA | 20 | |
| Rated short-time withstand current of the grounding switch | KA | 20 | |
| Ground switch rated short circuit duration | S | 4(2) | |
| Ground switch rated peak withstand current | KA | 50 | |
| Rated short-circuit shutdown current of the grounding switch | KA | 50 | |
| 1min rated frequency withstand voltage | Between phases, Phase to ground, Vacuum load switch opening distance | KV | 42 |
| | Disconnecting switch opening distance | KV | 48 |
| Rated lightning impulse withstand voltage | Between phases, Phase to ground, Vacuum load switch opening distance | KV | 75 |
| | Disconnecting switch opening distance | KV | 85 |
| Mechanical life | Vacuum load switch | time | 10000 |
| | Ground switch (knife switch), Disconnecting switch(knife switch) | time | 2000 |
| Crossover current | A | 3150 | |
| Overall dimensions | 800 (700) *900*2000 | mm | 200 ~ 300kg |



■ XGN15-12 type Indoor AC High-Voltage Metal-Enclosed Switchgear

Model Meaning

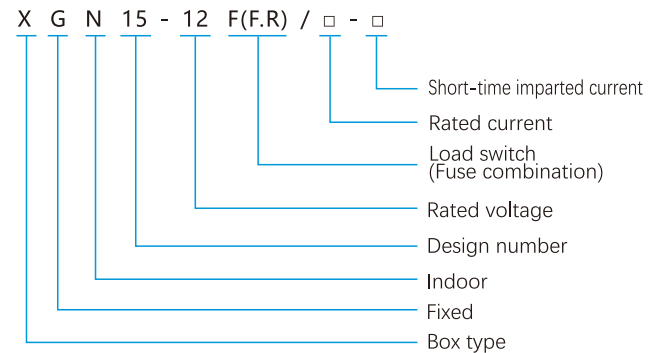

Product Overview and Features

Indoor AC high-voltage sulfur hexafluoride ring network switchgear (hereinafter referred to as "ring network cabinet") is a new generation of compact and expandable metal-enclosed switchgear with sulfur hexafluoride load switch as the main switch, and the whole cabinet adopts air insulation, which is suitable for power distribution automation. Ring main unit is characterized by simple structure, flexible operation, reliable interlocking, etc. It can provide satisfactory technical solutions for different applications and different user requirements. The adoption of sensing technology and the latest protection relay, coupled with advanced technical performance and lightweight and flexible assembly program. The use of sensing technology and the latest protection relays, coupled with advanced technical performance and lightweight, flexible assembly solutions, can fully meet the changing requirements of the market.

Main technical parameters

| Name | | Unit | Parameters | |
|--|--|---------------------------------|------------|---------------|
| Rated voltage | | KV | 12 | |
| Rated frequency | | Hz | 50 | |
| Rated current | | A | 630 | |
| Fuse rated current | | A | 125 | |
| Rated short-time withstand current | | KA | 25 | |
| Rated short circuit duration | | S | 2 | |
| Rated short-circuit closing current | | KA | 63 | |
| Rated peak withstand current | | KA | 63 | |
| Rated load breaking current | | A | 630 | |
| Rated transfer opening current (with 125A fuse) | | A | 1700 | |
| Rated breaking current of fuse (RMS) | | KA | 31.5 | |
| Rated insulation level | 1min frequency withstand voltage (RMS) | Between phases, Phase to ground | KV | 42 |
| | | Opening distance | KV | 48 |
| | Lightning impulse withstand voltage (Peak) | Between phases, Phase to ground | KV | 75 |
| | | Opening distance | KV | 85 |
| Secondary circuit 1min frequency withstand voltage | | KV | 2 | |
| protection class | | | IP3X | |
| Three-phase center distance | | mm | 210±2 | |
| Overall dimensions | load switch cabinet | Cabinet width | mm | 375, 500, 750 |
| | | Cabinet depth | mm | 940 |
| | | Cabinet height | mm | 1635, 1850 |
| | low voltage room | Heights | mm | 450 |
| Load switch mechanical life | Closing / Opening | time | 5000 | |
| | Breakout/Earthing | time | 1 000 | |



XGN66-12 type Cubicle-Type Fixed Metal-Enclosed Switchgear

Model Meaning

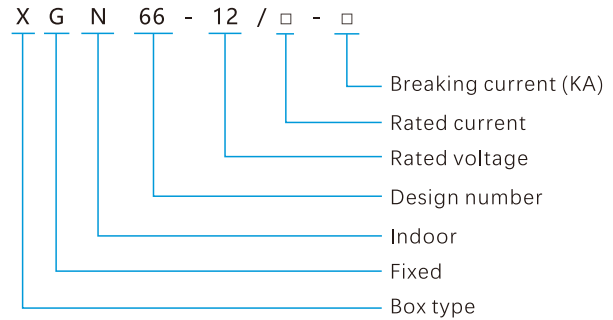

Product Overview and Features

The XGN66-12 fixed enclosed switchgear is our company's new generation high-voltage electrical complete set product, which complies with the international standard IEC60298 "1KV and above" Requirements for AC metal enclosed switchgear and control equipment below 52kV.

This product has advanced technology, small size, and good performance; The "five prevention" interlocking mechanism has advantages such as reliability and simplicity. The switchgear is an indoor complete set of equipment with 3.6, 7.2, and 12kV three-phase AC 50Hz single busbar segmentation. It has functions such as controlling, protecting, and monitoring circuits, and can be used in various types of power plants, substations, industrial and mining enterprises, high-rise buildings, etc. It can also be combined with the ring main unit and applied in switch stations.

Main technical parameters

| Name | Unit | Parameters |
|---|------|--|
| Switchgear | | |
| Rated Voltage | kV | 3.6、7.2、12 |
| Rated frequency withstand voltage | kV | Phase to ground,Between phases : 42;Opening distance: 45 |
| Rated lightning impulse withstand voltage | kV | Phase to ground,Between phases : 75;Opening distance: 85 |
| Rated frequency | Hz | 50 |
| Rated current | A | 630、1250 |
| Rated short-circuit breaking current (peak) | kA | 20、25、31.5 |
| Rated short-circuit closing current (peak) | kA | 50、63.80 |
| Rated dynamic stabilizing current (peak) | kA | 50、63、80 |
| Lightning thermal stabilizing current 4S (RMS) | kA | 20、25.31.5 |
| Protection class | | IP2X |
| Dimension(WXDXH) | mm | 900x 1000x2300 |
| Weight (WxDxH) | kg | ≈ 600 |
| Vs1- 12 type vacuum circuit breaker | | |
| Rated Voltage | kV | 12 |
| Rated current | A | 630 1250 |
| Rated short-circuit breaking current | kA | 2025 31.5 |
| Rated short-circuit closing current | kA | 50 63 80 |
| Rated short-time withstand current(4S RMS) | kA | 2025 31.5 |
| Rated peak withstand current (peak) | kA | 50 63 80 |
| Mechanical life | time | 10000 |
| Rated short-circuit breaking current breaking times | time | 50 |
| Rated operation sequence | | Switch off-0.35-Switch on-off180s-Switch on-off |



XGN2-12(Z) type Indoor Fixed Metal-Clad AC Switchgear

Model Meaning

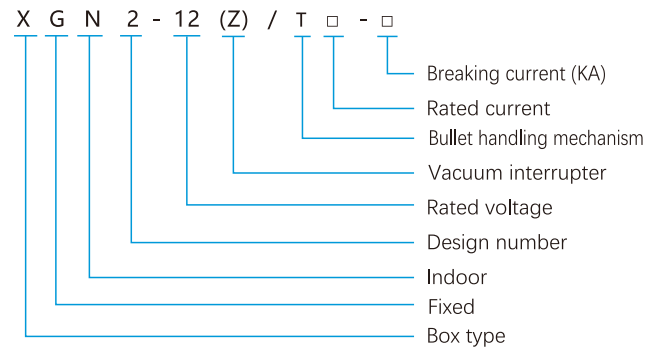

Product Overview and Features

Box-type fixed AC metal-enclosed switchgear (referred to as "switchgear"), suitable for rated voltage 3.6-12kV, 50Hz, rated current 630A ~ 3150A three-phase AC single bus, double bus, single bus with bypass system, as the acceptance and distribution of power, to meet the requirements of a variety of power plants, It can meet the requirements of power plants, substations and industrial and mining enterprises.

This product conforms to the standards: GB/T3906 "3~35kV AC metal-enclosed switchgear", GB/T11022 "Standard Common Technical Requirements for High-voltage Switchgear and Controlgear", IEC60298 "AC metal-enclosed switchgear and controlgear with a rated voltage of more than 1kV and less than 50kV".

Main technical parameters

| Name | Unit | Parameters | | | |
|--|------|---|-------|-----------|-----------|
| Switchgear | | | | | |
| Rated voltage (maximum working voltage) | kV | 3.6, 7.2, 12 | | | |
| Rated current | A | 630-3150 | | | |
| Rated Breaking Current | kA | 16, 20, 31.5, 40 | | | |
| Rated short-circuit closing current (peak) | kA | 40, 50, 80, 100 | | | |
| Rated short-circuit dynamic stabilizing current (peak) | kA | 40, 50, 80, 100 | | | |
| Rated thermal stabilization current | kA | 16, 20, 31.5, 40 | | | |
| Rated thermal stabilization time | S | 4 | | | |
| Protection class | | IP2X | | | |
| Busbar system | | Single busbar segmentation | | | |
| Operation mode | | Electromagnetic, spring loaded | | | |
| Dimension W*D*H | mm | 11 00X1200X2650(Normal type) | | | |
| Weight | kg | 1000 | | | |
| ZN28A-12 Vacuum interrupter | | | | | |
| Rated Voltage(Maximum Working Voltage) | KA | 12 | | | |
| Rated current | A | 630 | 1000 | 1250,2000 | 2500,3150 |
| Rated short-circuit breaking current | KA | 16,25 | 20,25 | 31.5 | 40 |
| Rated short-circuit closing current | KA | 40 | 50 | 80 | 100 |
| Rated dynamic stabilizing current (peak) | KA | 40 | 50 | 80 | 100 |
| Rated thermal stabilization current | KA | 16 | 20 | 31.5 | 40 |
| Arc ignition time | ms | 20 | | | |
| Rated operation sequence | | Switch off-0.3s-Switch on-off180s-Switch on-off | | | |
| One-minute frequency withstand voltage (RMS) | KV | 42 | | | |
| Lightning impact withstand voltage | KV次 | 75 | | | |
| Mechanical life | 次 | 10000 | | | |



GZDW type DC Power Cabinet

Model Meaning

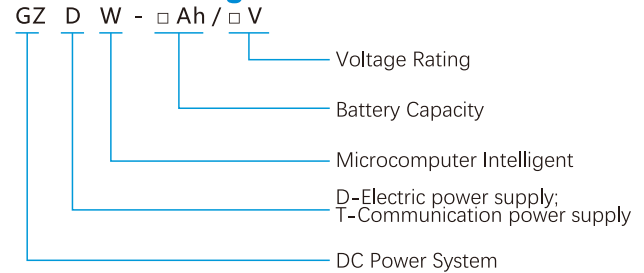

Product Overview and Features

GZDW DC power supply system is a new generation of DC power supply device, the system adopts the integrated design idea, which consists of monitoring module, rectifier module, insulation monitoring module, battery inspection module, switching quantity monitoring module, voltage reduction module and so on. It is characterized by advanced technology, reasonable configuration, intelligent measurement and control, and easy operation. It can communicate with the upper computer to realize the four remote functions conveniently, which is especially suitable for unattended needs.

Main technical parameters

| Name | Parameters |
|----------------------------------|---|
| AC Input | AC380V+ 15%, frequency 50Hz±10% |
| Output Voltage | 180V-286V arbitrary setting (220V system) , 90V- 143V arbitrary setting (1100V system) |
| Output Current | 20A (220V system), 20A (110V system) |
| Battery capacity | 100AH and below capacity DC systems |
| Rectifier Module | Our 10A and above rectifier modules |
| Module current limiting | 10%- 110% arbitrary settings |
| Operating efficiency | > 94% |
| Voltage Regulator Precision | < 0.5% |
| Ripple Coefficient | < 0.5% |
| Current Stabilization Precision | < 0.5% |
| Insulation resistance | > 10M Ω |
| Withstanding Voltage | 2kVAC no flashover, no breakdown for one minute |
| Battery Charge Management | Automation |
| Battery Temperature Compensation | User settable |
| Human Machine Interface | 320x 240 dot matrix LCD with Chinese character display, touch screen operation |
| Communication Interface | Support RS232 and RS485 two communication modes, provide RTU, CDT, MODBUS three kinds of communication protocol selection |
| Cabinet size: (HxWxD) mm | 2260x800x600 / 2360x800x600 |
| Color | Selectable |
| System wiring scheme | All wiring schemes |



SLVA

Standardized Low-Voltage (LV) Switchgear

Model Meaning

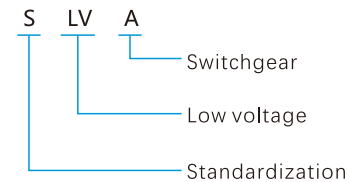

Product Overview and Features

SLVA low-voltage complete set of switchgear is a standardized design customized cabinet type, which standardizes the structural scheme, primary interface, secondary interface, civil interface, and main component parameters of the low-voltage switchgear. In the part of primary interface and civil interface, the system scheme and configuration requirements are streamlined to realize the unification of functional configuration, cabinet and cabinet to meet the requirement of interchangeability; the secondary principle, secondary interface and secondary marking are standardized to make the field personnel safer and more efficient in construction wiring and operation and maintenance; the technical parameters of the main components are standardized to achieve functional improvement and to provide a good solution for the future operation.

Main technical parameters

Correspondence between rated capacity of transformer and rated current of horizontal bus, etc.

| Transformer Rated capacity (kVA) | Horizontal busbar Rated current (A) | Horizontal busbar rated short-time withstand current (kA/1s) | Vertical busbar Rated current (A) | Vertical busbar rated short-time withstand current (kA/1s) | Horizontal busbar(A, B, C) Neutral conductor(N) Section specification (mm) | Protective wire (PE) Section specification (mm) |
|----------------------------------|-------------------------------------|--|-----------------------------------|--|--|---|
| 630 and below | 1250 | ≥ 35 | 1250 | ≥ 35 | 8×80 | 6×60 |
| 800、1000 | 2000 | > 50 | 1600 | ≥ 40 | 2, 10×80 | 10×80 |
| 1000、1250 | 2500 | ≥ 65 | 1600 | ≥ 50 | 2, 10×100 | 10×100 |

Note: 1.Vertical bus currents are only available for Option 4, Option 5, and Option 6.

2.The total load of the multi-circuit feeder cabinet shall be strictly controlled within the rated current of the vertical bus.

3.The branch buses in the inlet and busbar cabinets are consistent with the horizontal busbar specifications,

and the circuit breaker manufacturer's staking specifications are required to meet the requirements of this item.

Correspondence between rated capacity of transformer and rated current of horizontal bus, etc.

| Current value A | Chamber (drawer) width mm | Chamber (drawer) height mm |
|-----------------|---------------------------|----------------------------|
| 400 | 600 | 300 |
| 250 | 600 | 200 |

Correspondence between compensation capacity and main switch and branch rows

| Transformer rated capacity (kVA) | 500 | 630 | 800 | 1000 | 1250 |
|---|------|-----|-------|---|------|
| Total reactive power compensation capacity (kvar) | 150 | 200 | 240 | 300 | 360 |
| Minimum rated current of main switch (A) (Knife fuse switch or molded case circuit breaker optional) | 400 | 400 | 630 | 800 | 800 |
| Branch row specification(mm) | 6×30 | | 10×40 | 10×40 (Molded Case Circuit Breakers) 10×50 (knife fuse switch) | |

Note: The total reactive power compensation capacity consists of two parts: the total capacitor capacity and the total SVG capacity.



AGGD type AC Low-Voltage Distribution Cabinet

Model Meaning

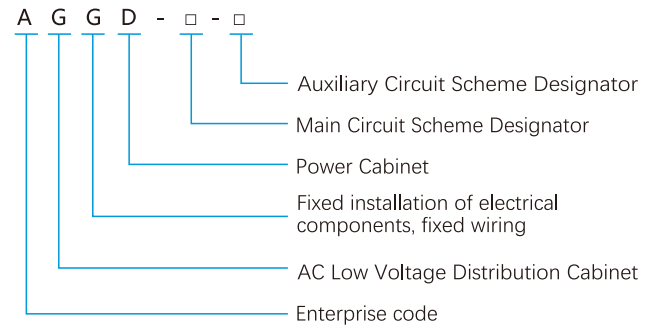

Product Overview and Features

AGGD type AC low-voltage distribution cabinet is suitable for power plants, substations, industrial enterprises and other power users as AC 50Hz, rated working voltage of 380V, rated current up to 3150A power distribution system as power. Lighting and distribution equipment for power conversion, distribution and control. The product has high breaking capacity, rated short-time withstand current up to 50kA. Line program flexibility, convenient combination, practicality, novel structure and other characteristics.

Main technical parameters

| Model | Rated voltage (V) | Rated current (A) | | | Rated short-circuit breaking current (kA) | Rated short-time withstand current (1S) (kA) | Rated peak withstand current (kA) |
|-------|-------------------|-------------------|----------|------|---|--|-----------------------------------|
| | | A | B | C | | | |
| GGD1 | 380 | 1000 | 600(630) | 400 | 15 | 15 | 30 |
| GGD2 | 380 | 1500(1600) | 1000 | 600 | 30 | 30 | 63 |
| GGD3 | 380 | 3150 | 2500 | 2000 | 50 | 50 | 105 |

Main circuit scheme

The main circuit program was selected after consulting the opinions of the majority of design and use of the Ministry (department), adding the program required by the power plant. The rated current is increased to 3150A, suitable for 2000kVA and the following distribution transformer selection.

In addition, in order to adapt to the needs of reactive power compensation designed AGZJ capacitor compensation cabinet, its main circuit 4 programs, a total of 1 2 specifications.

Auxiliary Circuit Solutions

The design of auxiliary circuits is divided into two parts: the power supply scheme and the power plant scheme, and there is enough space in the GGD cabinet to install secondary components.

Main busbar

Considering the price ratio and the feasibility of replacing copper with aluminum, single aluminum busbar is used when the rated current is 1500A and below, and double copper busbar is used when the rated current is more than 1500A. The manufacturer will manufacture the prototype in accordance with the regulations and pass the type test, and of course, the manufacturer can replace the aluminum busbar with the copper busbar of the same load capacity as the user's request.



AGCK type LV Withdrawable Switchgear

Model Meaning

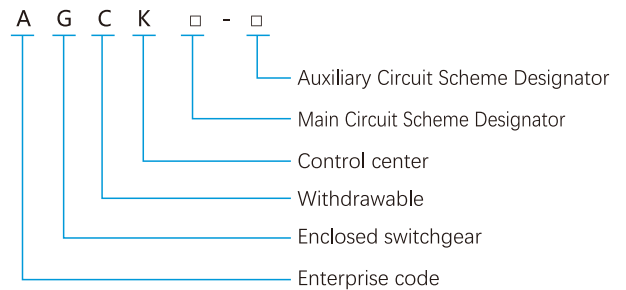

Product Overview and Features

Suitable for power plants, petroleum, chemical, metallurgy, textile, high-rise buildings and other industries in the power distribution system, in large power plants, petrochemical systems and other high degree of automation, the requirements of the interface with the computer place, as a three-phase AC frequency of 50 (60) Hz, the rated operating voltage of 380 (400) V, insulation voltage (660 V), the rated current for the generation of 4,000 A and the following power, power supply system in the distribution, centralized control of motors, reactive power compensation of the use of low-voltage power distribution equipment. .

Main technical parameters

| Name | Parameters |
|---|-------------------------------------|
| Rated insulation voltage | AC690V |
| Rated working voltage | AC380V(AC400V) |
| Horizontal busbar rated current | 1250A,1600A,2000A,3200A,4000A |
| Vertical busbar rated current | 1000A |
| Maximum current of feeder circuit | 2500A |
| Maximum current of drawer circuit | 630A |
| Maximum capacity of control motor | 320kW |
| Rated frequency | 50Hz |
| Horizontal busbar peak withstand current | 105kA,176kA |
| Horizontal busbar short-time withstand current (1s) | 50kA,80kA |
| Vertical busbar peak withstand current | 63kA,105kA |
| Vertical busbar short-time withstand current(1s) | 30kA,50kA |
| Rated frequency withstand voltage(1min) | 2500V |
| Secondary frequency withstand voltage(1min) | 2500V |
| Shell protection grade | IP40 |
| Shell size(mm) | W600(800,1000) x D800(1000) x H2200 |
| Effective height of functional unit(mm) | 1800 |



AGCS type LV Withdrawable Switchgear

Model Meaning

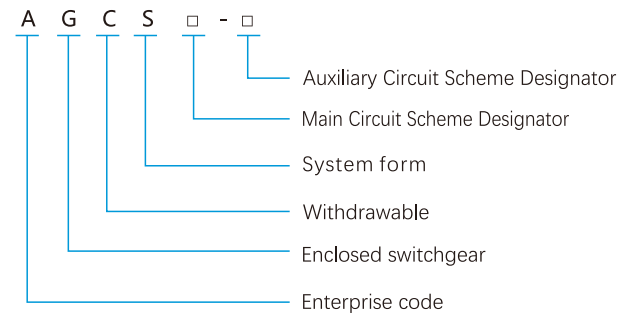

Product Overview and Features

Suitable for power plants, petroleum, chemical, metallurgy, textile, high-rise buildings and other industries in the power distribution system, in large power plants, petrochemical systems and other high degree of automation, the requirements of the place of interface with the computer, as a three-phase AC frequency of 50 (60) Hz, the rated operating voltage of 380 (400) V, insulation voltage (660 V), the rated current for the generation of 4,000 A and the following power, power supply system in the distribution, centralized control of motors, reactive power compensation of the use of low-voltage power distribution units.

Main technical parameters

| Name | Parameters |
|---|--------------------------------------|
| Rated insulation voltage | AC660 |
| Rated working voltage | AC380V(AC400) |
| Horizontal busbar rated current | ≤4000A |
| Vertical busbar rated current | 1000A |
| Maximum current of drawer circuit | 400A |
| Rated frequency | 50(60) |
| Horizontal busbar peak withstand current | 105,176 |
| Horizontal busbar short-time withstand current (1s) | 50,80 |
| Vertical busbar peak withstand current | 105 |
| Horizontal busbar short-time withstand current (1s) | 50 |
| Rated frequency withstand voltage(1min) | 2500 |
| Secondary frequency withstand voltage(1min) | 2500 |
| Shell protection grade | IP40 |
| Shell size(mm) | W600(800, 1000) x D800(1000) x H2200 |
| Effective height of functional unit(mm) | 1760 |



AMNS type LV Withdrawable Switchgear

Model Meaning

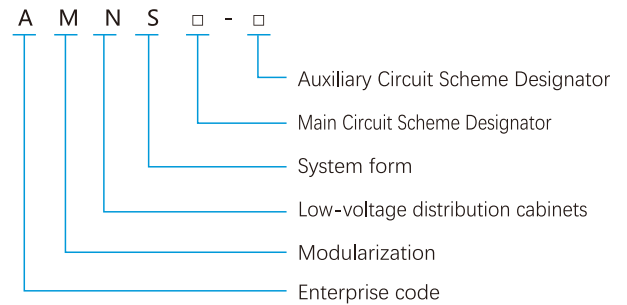

Product Overview and Features

Low-voltage withdrawable switchgear is a kind of modularized and multi-functional low-voltage power distribution, adopting the cabinet structure with high flexibility. According to different power equipment, many types of feeder units can be installed in the same row of cabinets or in the same cabinet, e.g., feeder circuits and motor control circuits can be mixed together. AMNS is a full range of low-voltage switchgear, which can satisfy your all-around needs, and it is suitable for all low-voltage systems up to 4,000A. AMNS can provide a high level of reliability and safety, and a humanized design, which strengthens the protection required for personal and equipment safety. Enhanced protection required for personal and equipment safety.

Main technical parameters

| Name | Parameters |
|---|-------------------------------------|
| Rated insulation voltage | AC690V |
| Rated working voltage | AC380V(AC400V) |
| Horizontal busbar rated current | 1250A, 1600A, 2000A, 3200A, 4000A |
| Vertical busbar rated current | 1000A |
| Maximum current of feeder circuit | 2500A |
| Maximum current of drawer circuit | 630A |
| Maximum capacity of control motor | 320kW |
| Rated frequency | 50Hz |
| Horizontal busbar peak withstand current | 105kA, 176kA |
| Horizontal busbar short-time withstand current (1s) | 50kA, 80kA |
| Vertical busbar peak withstand current | 63kA, 105kA |
| Vertical busbar short-time withstand current(1s) | 30kA, 50kA |
| Rated frequency withstand voltage(1min) | 2500V |
| Secondary frequency withstand voltage(1min) | 2500V |
| Shell protection grade | IP40 |
| Shell size(mm) | W600(800,1000) × D800(1000) × H2200 |
| Effective height of functional unit(mm) | 1800 |



AGDF type LV Withdrawable Switchgear

Model Meaning

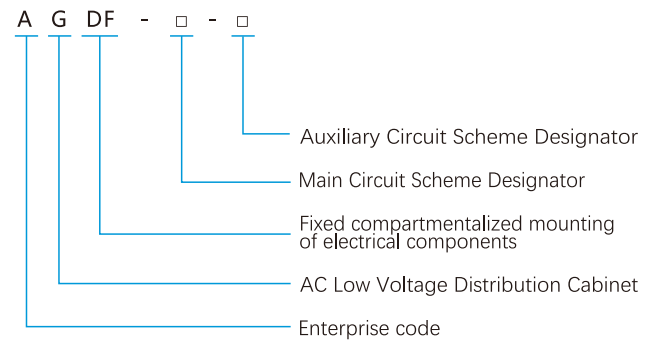

Product Overview and Features

AGDF type low-voltage fixed separated switchgear (hereinafter referred to as the device) is a low-voltage complete set of switchgear with advanced level developed by our company on the basis of extractable switchgear according to the special requirements of user's power distribution program and engineering applicability. The device is suitable for AC 50~60HZ, rated voltage 660V and below system, used for power generation, transmission, power conversion and general control of power consumption equipment.

Main technical parameters

| Name | Parameters |
|---|-------------------------------------|
| Rated insulation voltage | AC690V |
| Rated working voltage | AC380V(AC400V) |
| Horizontal busbar rated current | 1250A, 1600A, 2000A, 3200A, 4000A |
| Vertical busbar rated current | 1000A |
| Maximum current of feeder circuit | 2500A |
| Maximum current of drawer circuit | 630A |
| Maximum capacity of control motor | 320kW |
| Rated frequency | 50Hz |
| Horizontal busbar peak withstand current | 105kA, 176kA |
| Horizontal busbar short-time withstand current (1s) | 50kA, 80kA |
| Vertical busbar peak withstand current | 63kA, 105kA |
| Vertical busbar short-time withstand current(1s) | 30kA, 50kA |
| Rated frequency withstand voltage(1min) | 2500V |
| Secondary frequency withstand voltage(1min) | 2500V |
| Shell protection grade | IP41 |
| Shell size(mm) | W600(800,1000) x D800(1000) x H2200 |
| Effective height of functional unit(mm) | 1800 |



■ YBW-12/0.4 HV/LV Prefabricated Substation - Standardized Types (Metal, Non Metal)

Model Meaning

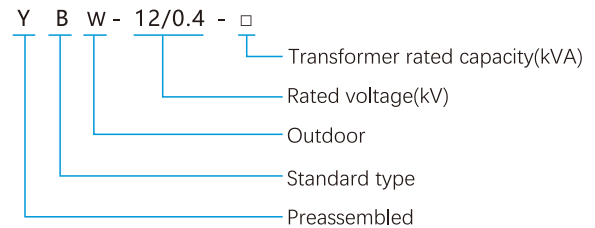

Product Overview and Features

YBW-12/0.4 high-pressure/low-voltage pre-assembled substation products are standardized design and customized standard solutions, in accordance with the company's "1135" distribution network operation and service management requirements, to improve equipment selection standards, improve quality control system, enhance the durability of the distribution network equipment, highlighting the core of the equipment is good, based on the safe and reliable, The design is based on the principles of safety, reliability, durability, standardization and universal interchangeability.

It is designed and launched based on the principles of safety, reliability, robustness, standardization and universal interchangeability of equipment from different manufacturers in a certain range and for a certain period of time, thus enhancing the convenience of operation and maintenance of the box-type substation. The product is equipped with an emergency power plug that can be connected to a power generator, and has the function of preventing the back-feeding of power, as well as the space reserved for the configuration of DTU automation terminals.

The product design is suitable for the area with sufficient permitted floor space and important power supply load, and is a new type of complete set of equipment for the construction and renovation of urban and rural substations.

Areas of application and environments of use

Widely used in coal mines, steel mills, hydroelectric power stations, solar photovoltaic projects and other outdoor places.

1. The surrounding air temperature: the highest temperature +40 °C, the lowest degree -25 °C;
2. Relative humidity:
Daily average relative humidity: ≤95%; daily average water vapor pressure does not exceed 2.2kPa;
Monthly average relative humidity: ≤90%; monthly average water vapor pressure does not exceed 1.8kPa;
3. Altitude: below 1000m;
4. Earthquake intensity: no more than 8;
5. The surrounding air should not be corrosive or combustible gases, water vapor and other obvious pollution sites;
6. No violent vibration places;

Main technical parameters

| Name | | Unit | Standard parameter values |
|--|-------------------|------|---|
| 12kV Ring network cabinet | | | |
| High-voltage side wiring method | | | Terminal type, ring type |
| Rated voltage | | kV | 12 |
| Rated frequency | | Hz | 50 |
| Rated current | | A | 630 (Load switches, circuit breakers) |
| Control mechanism | | | Motorized and manually operated |
| Temperature rise test current | | A | 1.1I _r |
| Rated industrial frequency 1min withstand voltage (relative to earth) | | kV | 42 |
| Rated lightning impulse withstand voltage peak (1.2/50μs, relative to earth) | | kV | 75 |
| Rated short-circuit breaking current | | kA | 31.5 (Fuse) |
| Rated short-circuit closing current | | kA | 50 |
| Rated short-time withstand current and duration | | kA/s | 20/3 |
| Rated peak withstand current | | kA | 50 |
| Short-time frequency withstand voltage for auxiliary and control circuits | | kV | 2 |
| Power supply | Control loop | V | DC 48/110/220, AC110/220 |
| | Auxiliary circuit | V | AC 380/AC 220 |
| Annual gas leakage rate | | V/V | ≤0.1% |
| Transformers | | | |
| Rated capacity | | kVA | 400、500、630 |
| Core Material | | | Silicon steel sheet |
| Rated voltage of high voltage winding | | kV | 10/10.5, Determined with the project unit prior to delivery |
| Rated voltage of low voltage winding | | kV | 0.4 |
| Tap range | | | ±2×2.5% |
| Linkage group | | | Dyn11 |
| Frame Circuit Breakers (0.4kV) | | | |
| Rated current | | A | 800、1000、1250 |
| Rated Working Voltage | | V | 400 |
| Rated insulation voltage | | V | 690 |
| The number of poles | | | 3P |
| Rated operating short-circuit breaking capacity | | kA | 65 |
| Rated peak withstand current | | kA | 80 |
| Molded Case Circuit Breakers (0.4kV) | | | |
| Rated current | | A | 250、400、630 |
| Rated Working Voltage | | V | 400 |
| Rated insulation voltage | | V | 690 |
| The number of poles | | | 3P |
| Rated operating short-circuit breaking capacity | | kA | 50 |
| Case Requirements | | | |
| Overall dimensions (L×W×H) | | mm | 3600×2200× (≤2500) |
| Shell material | | | Stainless steel or GRC |
| Protection class | | | IP33D |
| Enclosure level | | | 10 |



■ YJW-12/0.4 HV/LV Prefabricated Substation - Standardized Types (Metal, Non Metal)

Model Meaning

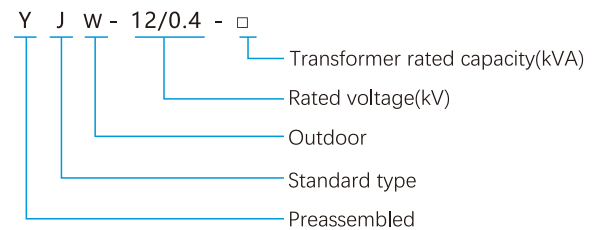

Product Overview and Features

YJW-12/0.4 high-voltage/low-voltage pre-assembled substation products are standardized design and customized compact solutions, in accordance with the company's "1135" distribution network operation and service management requirements, to improve equipment selection standards, improve the quality control system, enhance the durability of the distribution network equipment, highlighting the core of the equipment is good, based on the safe and reliable, The design is based on the principles of safety, reliability, durability, standardization and universal interchangeability.

It is designed and launched based on the principles of safety, reliability, robustness, standardization and universal interchangeability of equipment from different manufacturers in a certain range and for a certain period of time, thus enhancing the convenience of operation and maintenance of the box-type substation. The product is equipped with an emergency power plug that can be connected to a power generator, and has the function of preventing the back-feeding of power, as well as the space reserved for the configuration of DTU automation terminals.

The product design is suitable for the street and other places where the installation space is limited, and the power supply load is generally important, which is a new type of complete set of equipment for the construction and reconstruction of urban and rural substations.

Areas of application and environments of use

Widely used in coal mines, steel mills, hydroelectric power stations, solar photovoltaic projects and other outdoor places.

1. The surrounding air temperature: the highest temperature +40 °C, the lowest degree -25 °C;
2. Relative humidity:
Daily average relative humidity: ≤95%; daily average water vapor pressure does not exceed 2.2kPa;
Monthly average relative humidity: ≤90%; monthly average water vapor pressure does not exceed 1.8kPa;
3. Altitude: below 1000m;
4. Earthquake intensity: no more than 8;
5. The surrounding air should not be corrosive or combustible gases, water vapor and other obvious pollution sites;
6. No violent vibration places;

Main technical parameters

| Name | Unit | Standard parameter values |
|--|-------------------|---|
| 12kV Ring network cabinet | | |
| High-voltage side wiring method | | Terminal type, ring type |
| Rated voltage | kV | 12 |
| Rated frequency | Hz | 50 |
| Rated current | A | 630 (Load switches, circuit breakers) |
| Control mechanism | | Motorized and manually operated |
| Temperature rise test current | A | 1.1I _r |
| Rated industrial frequency 1min withstand voltage (relative to earth) | kV | 42 |
| Rated lightning impulse withstand voltage peak (1.2/50μs, relative to earth) | kV | 75 |
| Rated short-circuit breaking current | kA | 31.5 (Fuse) |
| Rated short-circuit closing current | kA | 50 |
| Rated short-time withstand current and duration | kA/s | 20/3 |
| Rated peak withstand current | kA | 50 |
| Short-time frequency withstand voltage for auxiliary and control circuits | kV | 2 |
| Power supply | Control loop | DC 48/110/220, AC110/220 |
| | Auxiliary circuit | AC 380/AC 220 |
| Annual gas leakage rate | V/V | ≤0.1% |
| Transformers | | |
| Rated capacity | kVA | 400、500、630 |
| Core Material | | Silicon steel sheet |
| Rated voltage of high voltage winding | kV | 10/10.5, Determined with the project unit prior to delivery |
| Rated voltage of low voltage winding | kV | 0.4 |
| Tap range | | ±2×2.5% |
| Linkage group | | Dyn11 |
| Molded Case Circuit Breakers (0.4kV) | | |
| Rated current | A | 250、400、630 |
| Rated Working Voltage | V | 400 |
| Rated insulation voltage | V | 690 |
| The number of poles | | 3P |
| Rated operating short-circuit breaking capacity | kA | 50 |
| Case Requirements | | |
| Overall dimensions (L×W×H) | mm | 2650×1350× (≤2100) |
| Shell material | | Stainless steel or GRC |
| Protection class | | IP33D |
| Enclosure level | | 10 |



AYB-12/0.4kV-1250 HV/LV Prefabricated Substation

Model Meaning

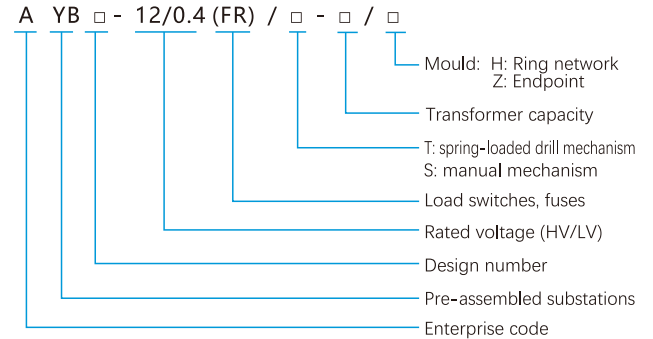

Product Overview and Features

It integrates high-voltage switchgear, transformers, and low-voltage switchgear into one, with strong completeness; Complete high and low voltage protection, safe and reliable operation, and simple maintenance; Small land occupation, low investment, short production cycle, and convenient mobility; Flexible and diverse wiring schemes;

Unique structure: The unique honeycomb structure double-layer (composite plate) shell is firm, insulated, ventilated, beautiful, and has a high level of protection. The shell materials include stainless steel titanium alloy, aluminum alloy cold-rolled plate, and color steel plate to choose from; Diverse types: universal, villa, compact, etc; The high-voltage ring main unit can be equipped with a network automation terminal (FTU) to achieve reliable detection of short circuits and single-phase grounding faults, with the "four remote" function, making it easy to upgrade the distribution network automation.

Main technical parameters

| Name | Unit | High Voltage Electrical Appliances | Transformers | Low-voltage electrics |
|--|---|---|--------------------|-----------------------|
| Rated voltage Ue | kV | 7.2/12 | 6/04、10/0.4 | 0.4 |
| Rated capacity Se | kVA | | "目"shape: 200~1250 | Maximum 2x 1250 |
| | | | "品"shape: 50-800 | |
| Rated current Ie | A | 200~ 630 | | 100-3000 |
| Rated Breaking Current | kA | Load switch 400-630A | | 15~63 |
| | | Combination of appliances depending on the fuse | | |
| Rated short-time withstand current (s) | kA | 20x(2) | 200-400kVA | 15x 1 |
| | | 31.5.50 | 400kVA | 30x1 |
| Rated peak withstand current | kA | 12.5x(4) | 200-400kVA | 30 |
| | | | 400kVA | 63 |
| Rated closing current | kA | 31.5、 50 | | |
| Frequency withstand voltage 1min | kV | Relative and inter-phase 30/42 | Oil-dip: 35/5min | 2kV at ≤ 300V |
| | | Disconnection 034/48 | Dry type: 28/5min | 2 5kV at 300,600V |
| Lightning strike | kV | Relative and inter-phase 60/75 | 75 | |
| | | Disconnect 075/85 | 75 | |
| Noise level | dB | | Oil-dip: <55 | |
| | | | Dry type: <65 | |
| Protection class | | | IP23D | |
| Overall dimensions | Depending on the program and the selected high and low voltage switchgear and transformers, different external dimensions are selected. | | | |



ZGS13-H-/10 series 10kV Ring-Main Unit Integrated Transformer - American Style

Model Meaning

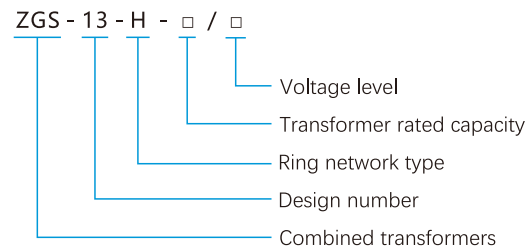

Product Overview and Features

The American style box type substation has a "品" - shaped structure, and is closely connected to high and low voltage equipment. The substation is exposed to the air on three sides, with good heat dissipation conditions, and can be separated from the high and low voltage equipment shell for easy maintenance.

The substation adopts S11 series oil immersed transformers with sheet oil tanks, no oil pillows, and fully enclosed. The high-voltage bushing, tap changer, oil level indicator, pressure relief valve, oil relief valve, etc. are all installed on the end plate of the high-voltage compartment, and the low-voltage bushing is installed on the end plate of the low-voltage compartment in a reasonable position for easy observation and operation.

The high voltage compartment and low voltage compartment are separated by steel plates. The high voltage compartment, low voltage compartment, and transformer are relatively independent while maintaining a complete box transformer as a whole. The structure is compact, the volume is small, and the weight is light. Install distribution switch equipment on the high and low voltage sides.

Areas of application and environments of use

It is widely used in various public places such as urban power grid renovation, residential neighborhoods, as well as indoor and outdoor places such as factories, mines, hotels, airports, railroads, wharves, highways and so on.

- 1、Cooling conditions: air self-cooling
- 2、Use environment:

Outdoor ambient temperature is not higher than 40°C, not lower than -25°C, the altitude does not exceed 1000m.

The average monthly temperature does not exceed 35°C, the average annual temperature does not exceed 20°C.

In 25 °C, the air compared to the humidity does not exceed 95%, the monthly average does not exceed 90%.

Horizontal acceleration is not more than 0.4m/s², vertical acceleration is not more than 0.2m/s².

The installation environment should be free from obvious dirt, explosive, corrosive gas and dust, and the installation place should be free from violent vibration and shock, and it is required to be installed on the cement platform or other flat and solid platform.

Main technical parameters

| Name | | Unit | Standard parameter values | |
|---|--|------|--|--------------------|
| Pre-assembled substations | | | | |
| Rated voltage | High voltage side | kV | 12 | |
| | Low voltage side | kV | 0.4. | |
| Transformer rated capacity | | kVA | 100, 125, 160, 200, 250 315, 400, 500, 630, 800, 1000 | |
| Pressure regulation without load | | | ±2x2.5% | |
| Connection method | | | △/Yn11 | |
| Rated insulation level | Lightning impulse withstand voltage (full wave, peak) | kV | 75 | |
| | Industrial frequency withstand voltage 1min | kV | 35 | |
| Low-voltage side frequency and voltage phase to phase and phase to ground (1min) | Main circuit | kV | 2.5 | |
| | Control and metering circuits | kV | 2.0 | |
| Noise level | | dB | 50 | |
| Protection class | | | Ip34 | |
| Cooling method | | | | |
| Load switch | | | Four-station | Two-station |
| Lightning surge withstand voltage (peak, full wave) | Ground-to-ground, interphase | kV | 75 | 75 |
| | Isolation InterrupGround-to-ground, interphase | kV | 85 | 85 |
| 1min frequency withstand voltage | Ground-to-ground, interphase | kV | 42 | 42 |
| | Isolation InterrupGround-to-ground, interphase | kV | 48 | 48 |
| Rated current | | A | 630 | 100 |
| Rated short-circuit closing current (peak) | | kA | 31.5 | 16 |
| Rated short-time withstand current | | kA | 12.5 | 6.3 |
| Rated short circuit duration | | S | 2 | 2 |
| Rated peak withstand current . | | kA | 31.5. | 16 |
| Mechanical life | | 次 | 2000 | 2000 |
| Transition time between main disconnections 0 in the case of division and closure | | ms | 16~22/15~20 | 11~15 |
| Fuse | | | | |
| Capacity(kVA) | Backup protection fuse rated current (A)/opening k (A) | | Insertion fuse rated current(A) | |
| 100 | 40/40 | | 10 | |
| 125 | 50/40 | | 15 | |
| 160 | 63/40 | | 25 | |
| 200 | 80/40 | | 25 | |
| 250 | 80/40 | | 25 | |
| 315 | 80/40 | | 25 | |
| 400 | 100/40 | | 40 | |
| 500 | 100/40 | | 40 | |
| 630 | 125/40 | | 65 | |
| 800 | 175/40 | | 65 | |
| 1000 | 200/40 | | 100 | |



■ YB-40.5 Wind Power Prefabricated Substation

Model Meaning

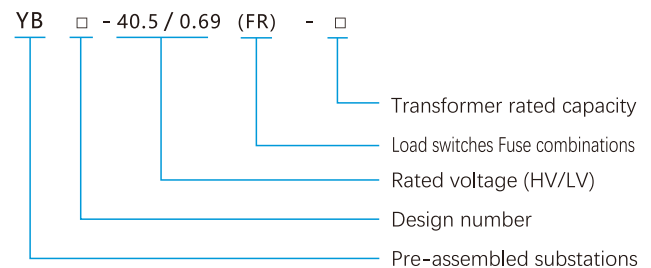

Product Overview and Features

Solar wind power box-type substation (hereinafter referred to as box-type transformer) is a kind of special equipment to increase the voltage of 0.275~0.69kV issued by wind turbine, and then output to the grid.

Differing from the traditional box-type substation, the high-voltage load switch, fuse, and high-voltage components and transformer body, non-excited tap changer are sealed in the same oil chamber respectively, with compact structure. Flexible installation of switchgear on the low voltage side.

Main technical parameters

| Name | Unit | Standard parameter values |
|--|------|--|
| High Voltage Unit | | |
| Rated Frequency | Hz | 50 |
| Rated Voltage | kV | 35 |
| Maximum working voltage | kV | 40.5 |
| Rated current | A | 400、630、1250 |
| Transfer current | A | 1200~3150 |
| Frequency withstand voltage to ground and phase-to-phase/isolated breaks | kV | 42/48 |
| Lightning impulse withstand voltage to ground and phase-to-phase/isolated breaks | kV | 75/85 |
| Rated short-circuit breaking current (current limiting fuse) | kA | 31.5 |
| Transformer unit | | |
| Rated voltage | kV | 35 |
| Rated capacity | kVA | 50-1600 |
| Tap range | % | +2*2.5% , +5% |
| Connection group | | Yyn0、 Dyn11 |
| Impedance voltage | % | 4、 4.5.6、 8 |
| Low Voltage Unit | | |
| Rated voltage | V | 220、 380、 690. 800 |
| Main circuit rated current | A | 50-4000 |
| Branch circuit current | A | 5-500 |
| Case Requirements | | |
| Protection level (conventional products) | | High-voltage room IP33;Transformer room IP23;Low-voltage room IP33 |
| Noise level | dB | ≤50 |



AZBW-35

35kV Integrated Substation - American Type

Model Meaning

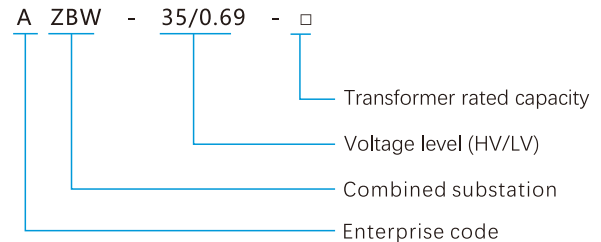

Product Overview and Features

Solar wind power box-type substation (hereinafter referred to as box-type transformer) is a kind of special equipment to increase the voltage of 0.275~0.69kV issued by wind turbine, and then output to the grid.

Differing from the traditional box-type substation, the high-voltage load switch, fuse, and high-voltage components and transformer body, non-excited tap changer are sealed in the same oil chamber respectively, with compact structure. Flexible installation of switchgear on the low voltage side.

Main technical parameters

| Name | Unit | Standard parameter values | | |
|---|---|---------------------------|---|-------------|
| Wind power substation | | | | |
| Rated voltage | Original margin | kV | 35 | |
| | Hypotenuse | kV | 0.69 | |
| Transformer rated capacity | | | 31 5,400, 500,630, 800, 1000,1250,1600 | |
| Pressure regulation without load | kVA | | ±2x2.5% | |
| Connection method | | | Dyn11 | |
| Rated insulation level | Lightning impulse withstand voltage (full wave, peak) | | 200 | |
| | Industrial frequency withstand voltage 1min | | 85 | |
| Low-voltage side frequency and voltage phase to phase and phase to ground (1min) | Main circuit | kV | 2.5 | |
| | Control and metering circuits | kV | 2.0 | |
| Noise level | kV | | 60 | |
| Protection class | kV | | IP54(Oil tank IP68, high and low pressure chamber IP54) | |
| Cooling method | dB | | Oil immersion self-cooling | |
| Load switch | | | Four-station | Two-station |
| Lightning surge withstand voltage (peak, full wave) | Ground-to-ground, interphase | kV | 200 | 200 |
| | Isolation InterrupGround-to-ground, interphase | kV | 215 | 215 |
| 1min frequency withstand voltage | Ground-to-ground, interphase | kV | 90 | 90 |
| | Isolation InterrupGround-to-ground, interphase | kV | 110 | 110 |
| Rated current | A | | 630 | 300 |
| Rated short-circuit closing current (peak) | kA | | 31.5 | 16 |
| Rated short-time withstand current | kA | | 12.5 | 6.3 |
| Rated short circuit duration | S | | 2 | 2 |
| Rated peak withstand current . | kA | | 31.5. | 16 |
| Mechanical life | 次 | | 2000 | 2000 |
| Transition time between main disconnections 0 in the case of division and closure | ms | | 16~22/15~20 | 11~15 |



■ ZN63A(VS1)-12

Indoor AC High Voltage Vacuum Circuit Breaker

Model Meaning

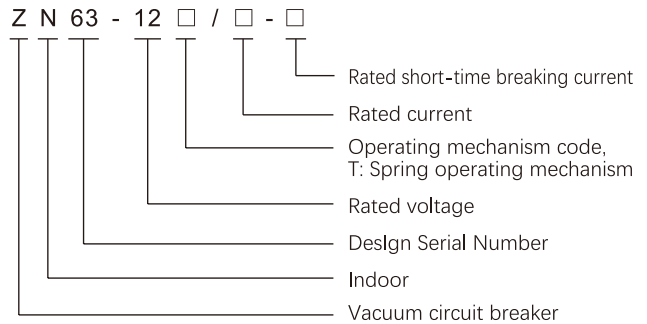

Product Overview and Features

ZN63A-12 (VS1) indoor AC high-voltage vacuum circuit breaker is suitable for switching various types of loads in three-phase AC 50Hz, rated voltage 12kV and below power systems.

It can be used for the protection and control of electrical equipment in industrial and mining areas, enterprises, power plants, and substations. It can be equipped with center mounted handcart switchgear such as KYN28A-2 (GZS1), and can also be fitted with other fixed switch sets.

Main technical parameters

| Item | Unit | Parameters | | |
|---|---|------------------------------|----|------------------------|
| Rated voltage | kV | 3.6、7.2、12 | | |
| Rated frequency | Hz | 50 | | |
| Rated current of circuit breaker | A | 630、1250、1600、2000、2500、3150 | | |
| Rated peak withstand current (peak) | kA | 40、50、63、80、100 | | |
| Rated short-time withstand current (4S) | kA | 20、25、31.5、40 | | |
| Rated short circuit breaking current | kA | 20、25、31.5、40 | | |
| Rated short-circuit closing current (peak) | kA | 50、63、80、100 | | |
| Rated insulation level | 1-minute power frequency withstand voltage | Pole to pole, pole to ground | kV | 24、32、42 |
| | | Between open contacts | kV | 24、32、48 |
| | Lightning impulse withstand voltage | Pole to pole, pole to ground | kV | 40、60、75 |
| | | Between open contacts | kV | 46、70、85 |
| Rated operating sequence | Open -0.3 seconds - close/open -180 seconds - close/open; 40KA opening -180 seconds - closing and opening -180 seconds - closing and opening | | | |
| Rated breaking current of a single capacitor bank | A | 630 | | |
| Back to back capacitor bank breaking current | A | 400 | | |
| Operating mechanism | Energy storage motor | Rated voltage | V | AC110、220; DC110、220 |
| | | Output power | W | 70 |
| | Opening and closing coils | Rated voltage | V | AC110、220; DC110、220 |
| | | Coil power | W | 440 (close) 368 (open) |



Zw32

Outdoor AC High Voltage Vacuum Circuit Breaker

Model Meaning

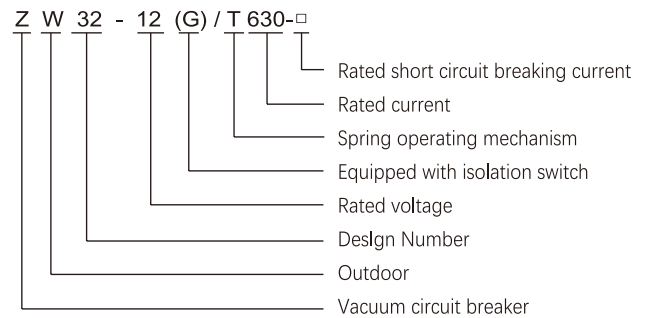

Product Overview and Features

ZW32-12 series outdoor AC high voltage vacuum circuit breaker is a three-phase AC 50Hz outdoor high voltage switchgear mainly used in 10kV rural and urban power systems. It is used for breaking and closing load currents, overload currents, and short-circuit currents, and can also be used in other similar places. ZW32-12 series outdoor AC high-voltage vacuum circuit breakers comply with standards such as IEC 60056 《High Voltage AC Circuit Breakers》 of the International Electrotechnical Commission.

Main technical parameters

| Item | Unit | Parameters |
|--|--------------|--|
| Rated voltage | kV | 12 |
| Rated current | A | 630 |
| Power frequency withstand voltage (1min) | kV | 42 |
| Lightning impulse withstand voltage (peak value) | kV | 75 |
| Rated short circuit breaking current | kA | 12.5、16、20 |
| Rated short-circuit closing current (peak) | kA | 31.5、40、50 |
| Rated peak withstand current | kA | 31.5、40、50 |
| 4s rated short-time withstand current | kA | 12.5、16、20 |
| Rated operating sequence | kA | Open -0.3s - close/open -180s - close/open |
| Rated short-circuit breaking current breaking times | time | 30 |
| Mechanical life | time | 10000 |
| Rated voltage of energy storage motor | V | DC or AC 220、110、DC24 |
| Rated operating voltage (Equipped dedicated spring operating mechanism) | Trip coil | V DC or AC 220、110、DC24 |
| | Closing coil | |
| Rated current of overcurrent release device | A | 5 |
| Allowable wear thickness of dynamic and static contacts | mm | 3 |
| Quality | kg | 108、138 (Unilateral isolation) |
| Center distance between poles | mm | 340±3 |